



Vertical cassette blind

markilux 620 tracfix

Slender and stable in wind with tracfix cover guidance system.

Product properties

Wind resistance class 3

Beaufort 6 → 38–48 km/h → 10.5–13.4 m/s → 24–30 mph

01

02

03

04

05

06

07

08

09

10

11

12

13

14

15

16

17

18

19

20

side view

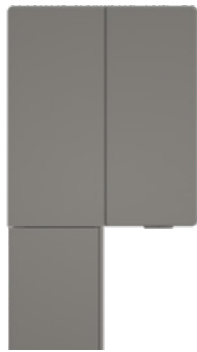

unit when closed



reveal fixture



front profile finishes flush with the end of the guide rails

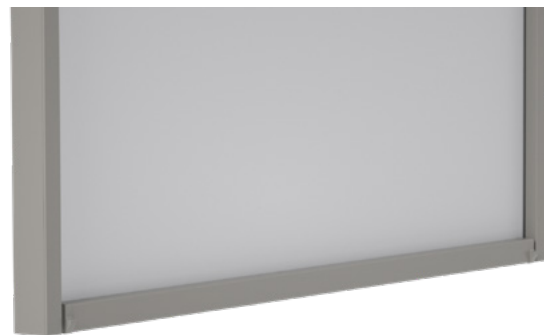

with tracfix system, the continuous lateral cover guidance system that leaves no gap between the cover and guide rails



cover guidance system in the tracfix profile

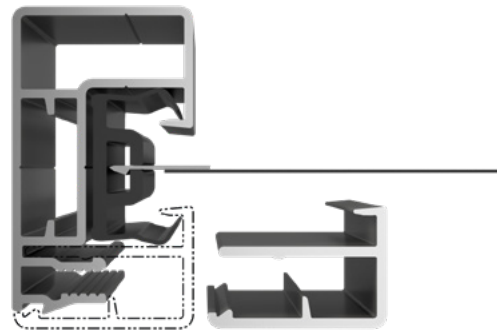

section of guide rail with tracfix profile



Product properties

Description

- slender, compact vertical cassette blind with angled guide rails and gravity-fed cover tensioning system – for areas up to 12 m².

Special features

- fully encompassing cassette that protects the cover perfectly
- attractive appearance without visible screws
- supplied as standard with a hard-wired motor
- with tracfix system, the continuous lateral cover guidance system that leaves no gap between the cover and guide rails – gives improved wind stability and a cleaner appearance
- good blind closure guaranteed by virtue of the small protuberances on the bottom profile end caps that close firmly against the cassette
- fixture directly through the angled rails – the cassette is positioned right against the wall

Dimensions

- single unit: 61 cm – 400 cm in width, maximum height 400 cm (depending on the width)
- maximum width × height: 300 cm × 400 cm / 400 cm × 300 cm
- intermediate sizes are available

Roller tube and lateral bearings

- round roller tube Ø 63 mm with keyway, galvanised steel
- the roller tube bearing is made of stainless steel

Blind profiles

- extruded aluminium, in façade quality, powder coated
- cassette profile in one piece, oblong, height × depth 110 mm × 95 mm
- angled guide rails in two pieces, width × depth 27 mm × 48 mm
- bottom profile angular, height × depth 32 mm × 40 mm

Side caps

- the cassette end caps are made of die-cast aluminium, powder coated
- the bottom profile end caps are made of high-quality plastic, powder coated

Fixture brackets

- self-supporting cassette attached to the top of the angled guide rails
- without brackets, fixture directly through the angled guide rails, face or reveal fixture

01 **Frame colours**

02 markilux blind colours without surcharge

03 traffic white RAL 9016

04 metallic aluminium RAL 9006

05 grey brown, similar to RAL 8019

09 off-white textured finish, 5233 ¹⁾10 stone grey metallic, 5215 ¹⁾11 anthracite metallic, 5204 ¹⁾15 Havana brown textured finish, 5229 ¹⁾17 **Non-standard powder-coated finish**18 Bespoke frame colours at a surcharge – matt, metallic and pearl finishes as well as other colour ranges (DB, Tiger etc.) on request.
19 All frame colours are available at a surcharge with enhanced corrosion protection.20 **1)** textured finish

Colours may differ slightly from those depicted in both hue and finish.

Dimensions and configuration options

Single unit

		Overall blind width						Blind minimum width		
		100	150	200	250	300	350	400	Hard-wired motor	Radio-controlled motor
Order dimensions		61	101	151	201	251	301	351	64	77
		100	150	200	250	300	350	400		
AH	120 ¹⁾								64	77
	160									
	200									
	250									
	300									
	350						—	—		
400						—	—			

1) = smallest possible unit height 65 cm

AH = unit height

dimensions in cm

Operation	standard	optional	Coupled Blind
crank handle	—	—	not available
crank handle, operation from the rear	—	—	
crank handle, operation from inside the building	—	—	Optional accessories
hard-wired motor	✓	—	automatic controls (light, wind, rain)
radio-controlled motor io, 868 MHz	—	✓	N.B! Important background information can be found in the chapter "Optional Accessories".
radio-controlled motor RTS, 433 MHz	—	✓	

Blind cover	fabric range no.	standard	optional	overall blind width	unit height	cover manuf.
sunvas	301.. / 309..-315..	✓	—	≤ 300	≤ 300	LN
sunsilk	324.. / 325.. / 328.. / 369..	✓	—	≤ 300	≤ 300	LN
perfortex	331.. / 332..	✓	—	≤ 300	≤ 300	LN
sunvas (250 cm)	31008, -09, -13, -16, -18, -25, -27, -28, -31, -36, -37, -57, -58, 31109, -14, -17	✓	—	≤ 250	≤ 240	N
				≥ 251 ≤ 300	≤ 240	N
transolair	338..	—	✓	≥ 251 ≤ 300	≥ 241	QN
				≥ 301	≤ 300	LN
transolair (120 cm)	339..	—	✓	≤ 300	≤ 300	LN
sunvas (320 cm)	31008, -09	✓	—	≤ 300	≤ 300	N
				≥ 301	≤ 300	LN
vuscreen Alu	317..	—	✓	≤ 250	≤ 250	N
				≤ 300	≤ 300	N
Fibreglass Screen Fabrics	272..	—	✓	≥ 251 ≤ 300	≤ 240	N
				≥ 251 ≤ 300	≥ 241 ≤ 300	QN
				≥ 300	≤ 300	LN
Soltis Perform 92	92-20..	—	✓	≤ 177	≤ 170	N
				≥ 178 ≤ 300	≤ 170	N
				≥ 178 ≤ 300	≥ 171	QN
				≥ 301	≤ 300	LN
perla	370..	—	—			
perla FR	374.. / 375..	—	—			

dimensions in cm

N = seamless

LN = vertical seam(s), panel width usually 120 cm

QN = horizontal seam(s)

Dimension overview

Single unit

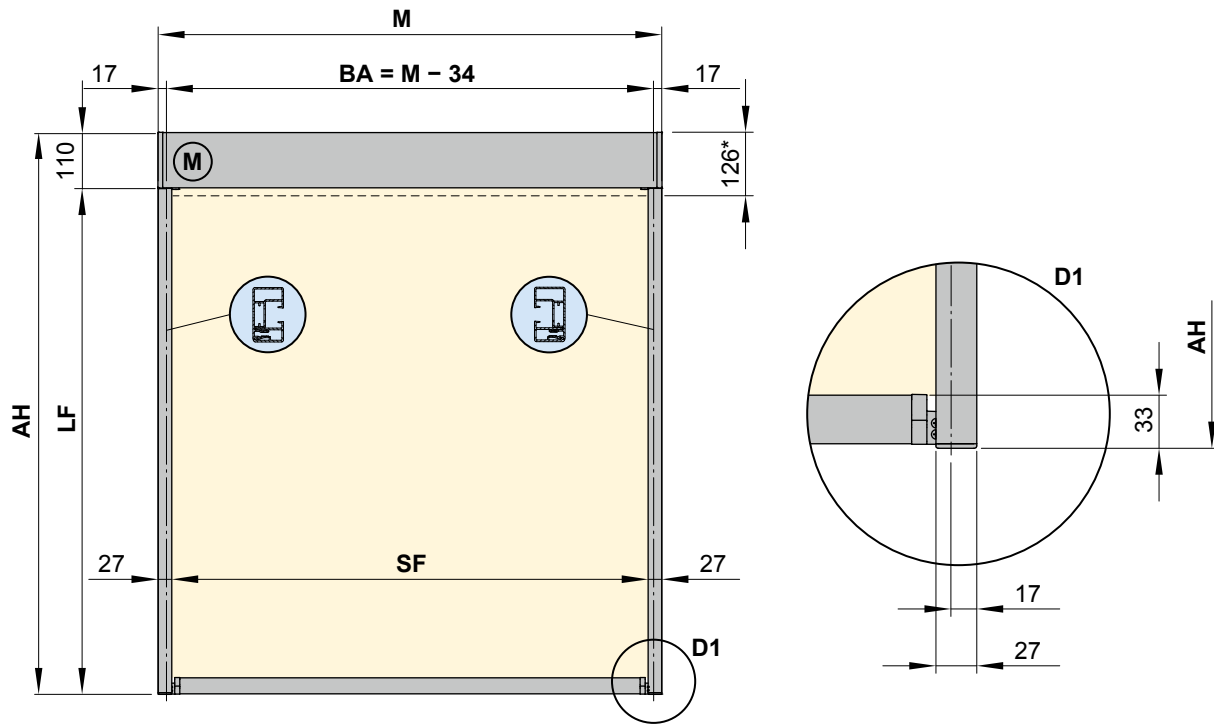

Two single units

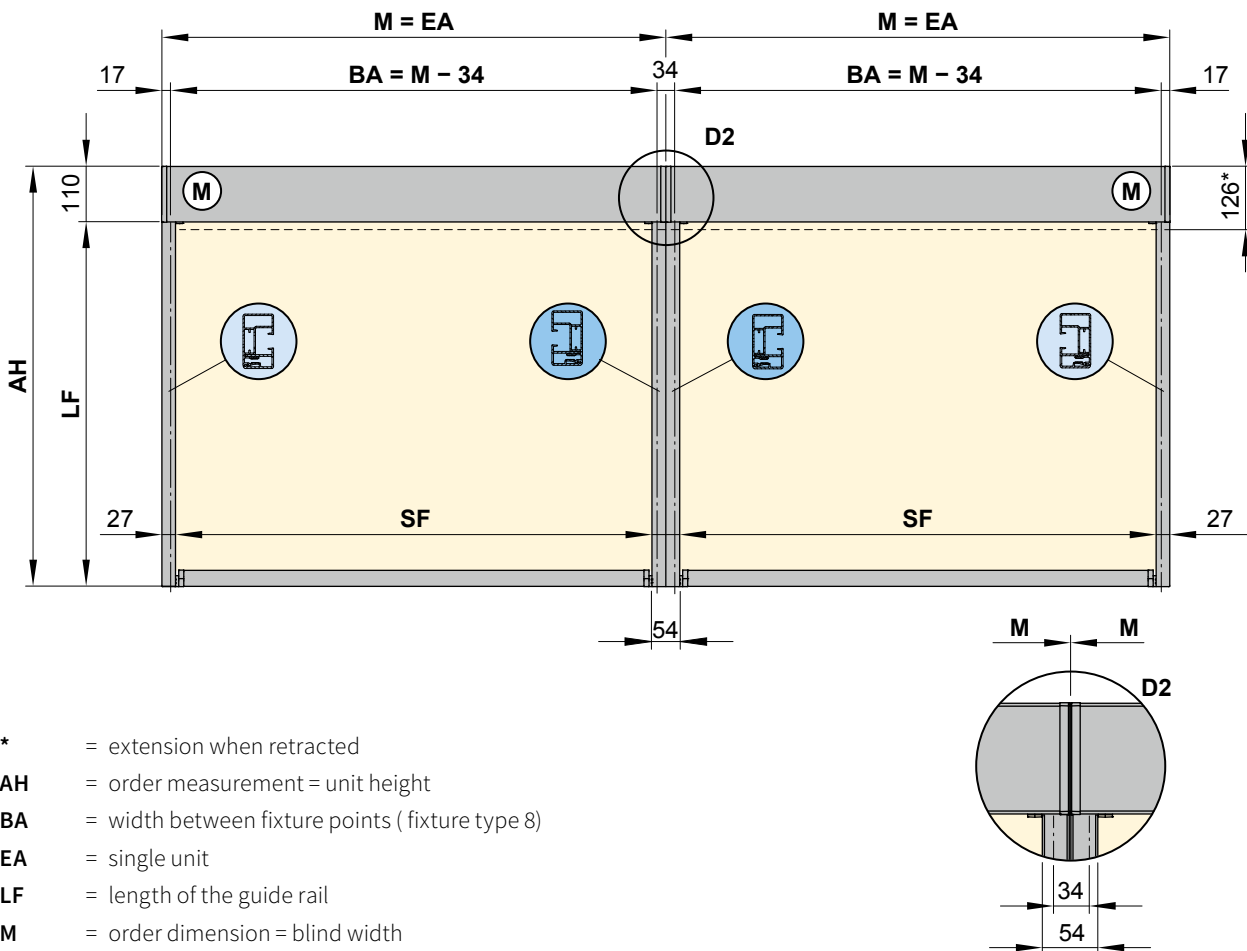

- * = extension when retracted
- AH = order measurement = unit height
- BA = width between fixture points (fixture type 8)
- EA = single unit
- LF = length of the guide rail
- M = order dimension = blind width
- (M) = motor
- SF = visible cover area

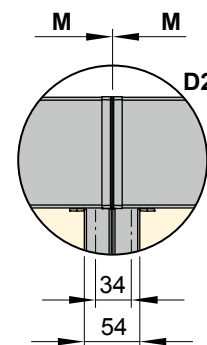

dimensions in mm

Dimension overview fixture combination 8

Face fixture

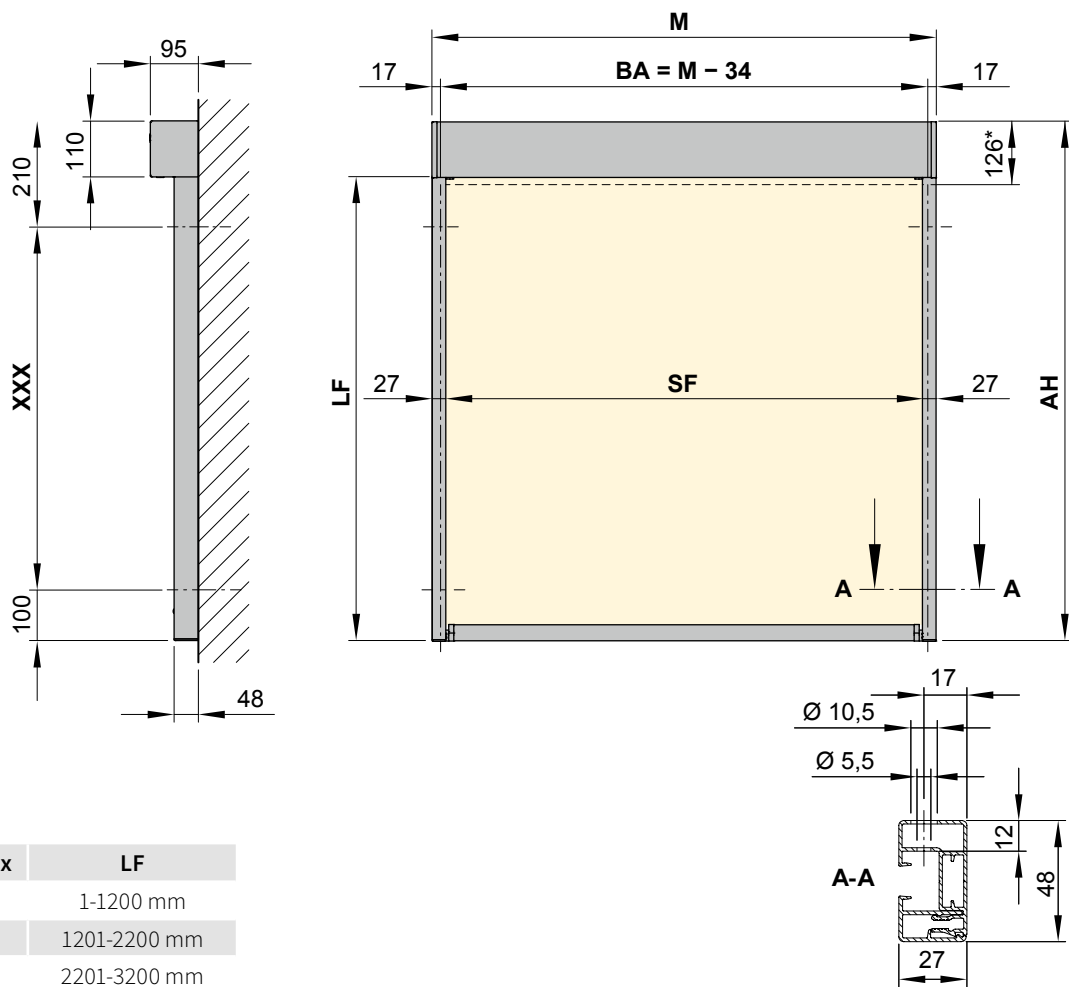

ABO - xxx	LF
2	1-1200 mm
3	1201-2200 mm
4	2201-3200 mm
5	3201-4000 mm

- * = extension when retracted
- AH = order measurement = unit height
- ABO = number of drill holes in the range xxx
- BA = width between fixture points

- LF = length of the guide rail
- M = order dimension = blind width
- SF = visible cover area

dimensions in mm

01
02
03
04
05
06
07
08
09
10
11
12
13
14
15
16
17
18
19
20

Dimension overview fixture combination 9

Reveal fixture

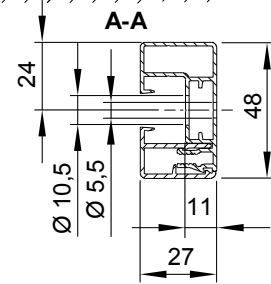
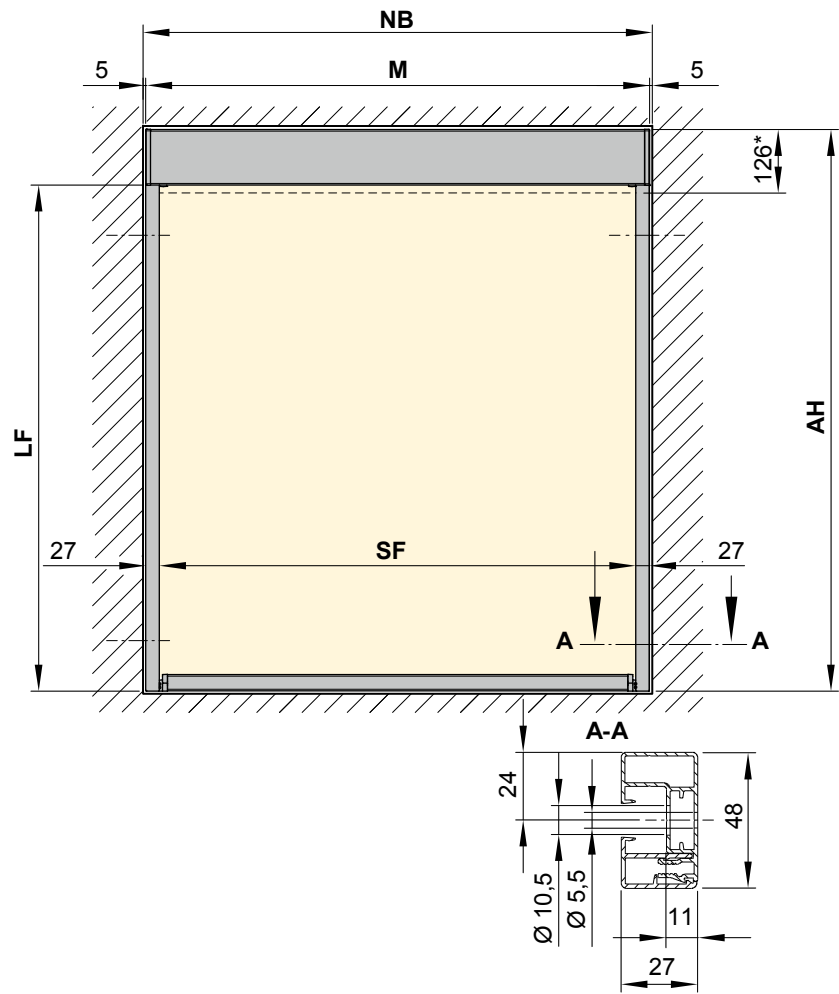
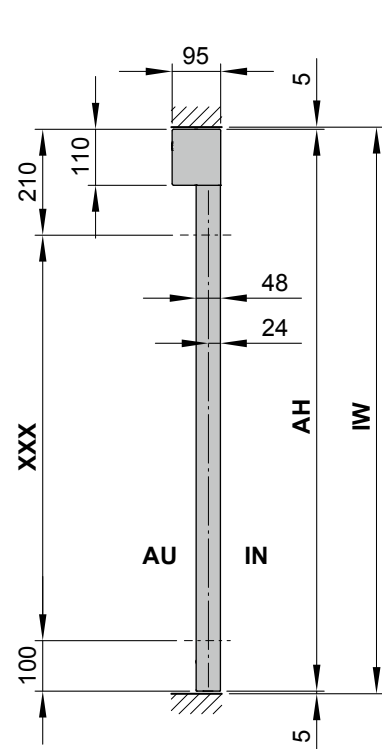

ABO - xxx	LF
2	1-1200 mm
3	1201-2200 mm
4	2201-3200 mm
5	3201-4000 mm

- * = unit height when retracted
- AH = order measurement = unit height = IW - 10 mm
- AU = exterior
- ABO = number of drill holes in the area xxx
- IN = interior
- IW = height of opening

- LF = length of the guide rail
- M = order dimension = blind width
- MA = blind fixture width
- NB = reveal width
- SF = visible cover area

dimensions in mm

Reveal fixture in a top window well

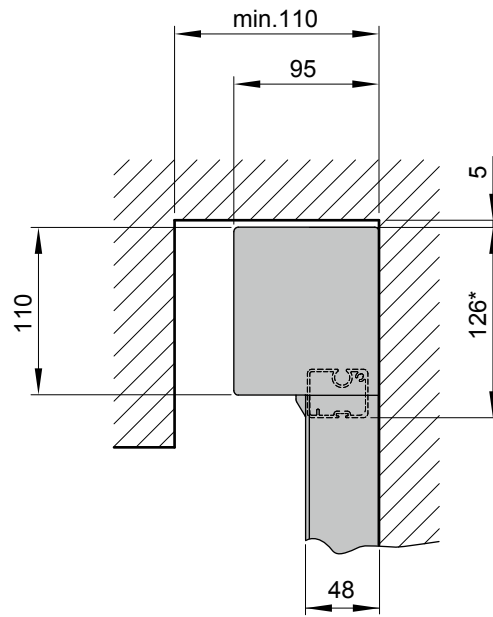

Motor cable exit point

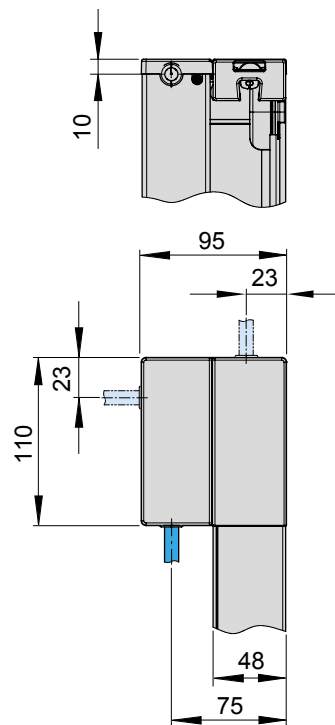

* = unit height when retracted

- = standard
- = optional

dimensions in mm

01
02
03
04
05
06
07
08
09
10
11
12
13
14
15
16
17
18
19
20

sundrive dimension overview

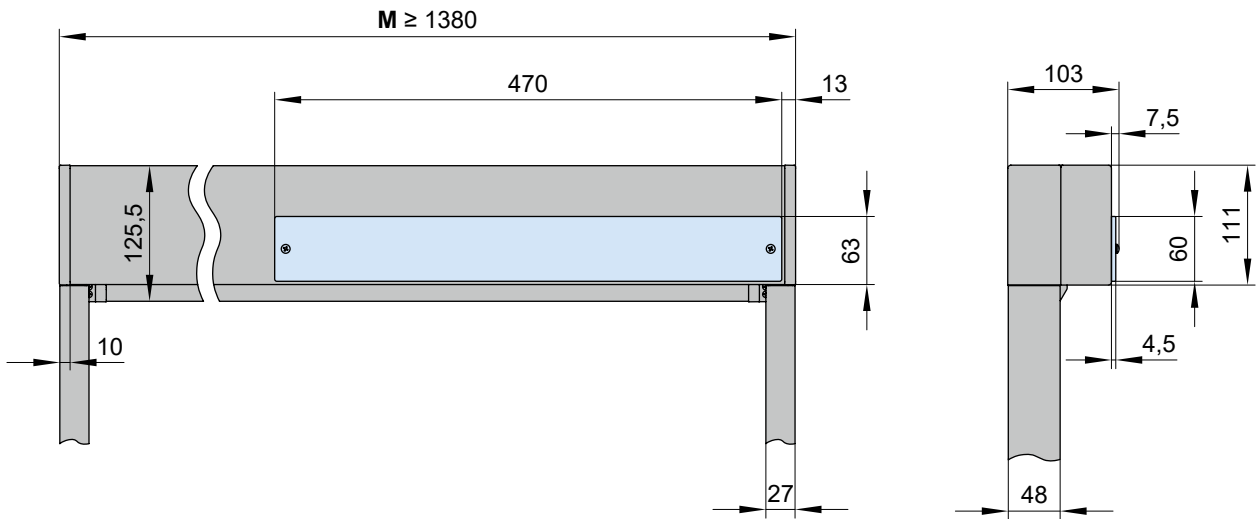

Dimension overview for sundrive with E-box

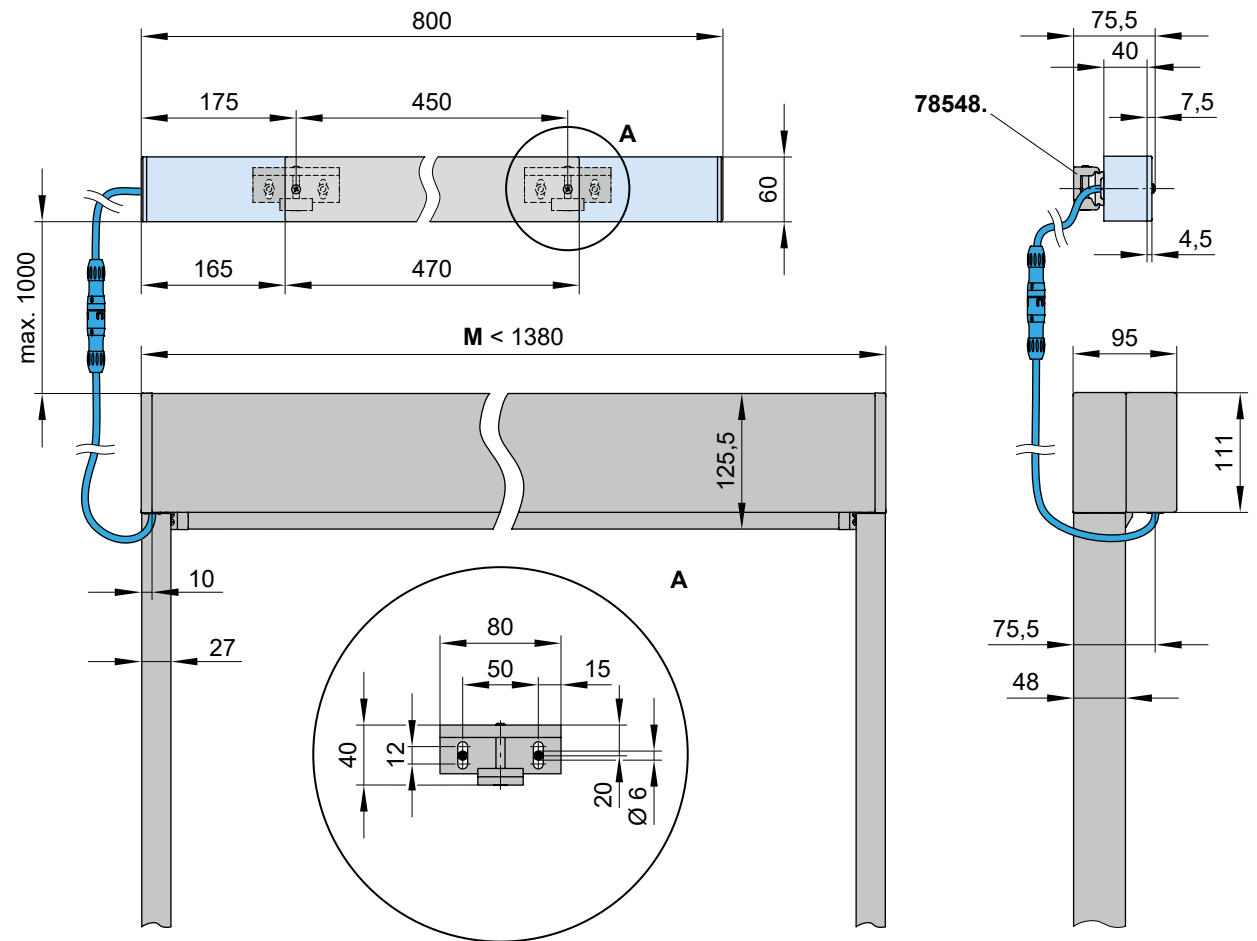
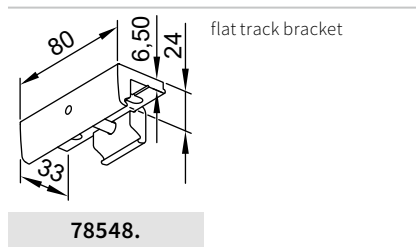

M = order dimension = awning width
 78548. = track bracket

dimensions in mm

Motor cable exit point for sundrive with E-box

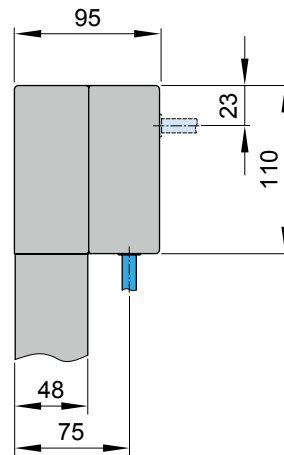

= standard
 = options

Technical data of radio-controlled motor RTS (433 MHz)

Operating voltage	12 V DC
Power output	32 W
Protection class	IP 44

Technical data of solar module

Operating voltage	max. 21 V DC
Current	max.196 mA
Power output	3,2 W
Protection class	IP 44

dimensions in mm

01

02

03

04

05

06

07

08

09

10

11

12

13

14

15

16

17

18

19

20