



## **markilux 5010**

**The cassette awning – slim, strong and simply stylish**

**rated to wind resistance class 2  
(corresponds to Beaufort 5)**



side view with awning retracted, face fixture (top fixture is optional)



side view with awning retracted showing gearbox eye for manual operation (standard)

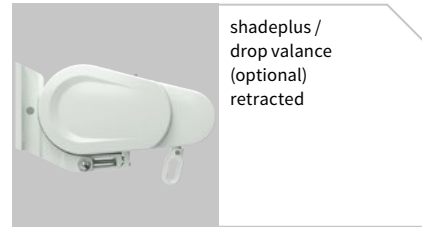

shadeplus / drop valance (optional) retracted



markilux 5010 with wall sealing profile (optional)

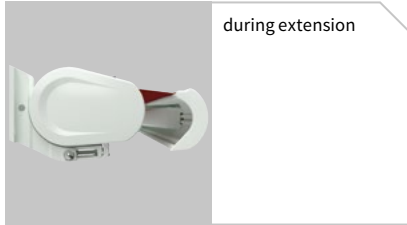

during extension

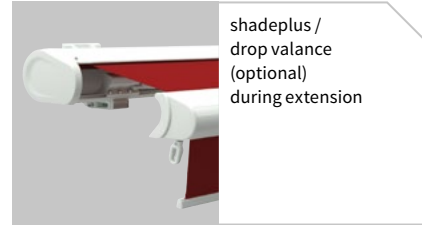

shadeplus / drop valance (optional) during extension



corrosion-resistant and technically proven; twin steel-link chains



pitch adjustment via the fixture brackets

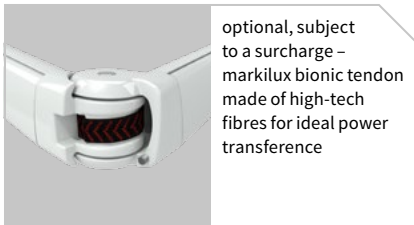

optional, subject to a surcharge – markilux bionic tendon made of high-tech fibres for ideal power transference

### Design Features

the slim cassette awning with the elegant contours – from the design studio

the cover profile is in the same colour as the cassette; this provides for a closed appearance even when the awning is extended

attractively shaped, rounded end caps complete the appearance of this slender cassette awning

attractive brackets; design down to the last detail

### Technical Specification

in spite of its slender shape the superior design of the markilux 5010 means that it is amongst the sturdiest and most robust of full cassette awnings on the market

the 85 mm roller tube ensures the highest stiffness and the best possible cover winding characteristics even at the largest widths

front profile with integrated gutter and hidden water drainage spouts

when closed the folding arms are protected from the weather by the cassette

### Optional Accessories

the shadeplus creates an additional room on the patio. Protection from the sun, the wind and inquisitive glances all in one

radio-controlled motor with radio remote control for ease of use

hard-wired motor operation (optionally with automatic weather controls) for straightforward and easy operation

in the case of manual operation ease of use is ensured with the spring-assisted gearbox

wall sealing profile to cover the gap between awning and wall

awning available in non-standard RAL colours

available with bionic tendon

available with a valance

awnings with 2 folding arms are available with the innovative silentec technology

### Lounge colours

off-white textured finish 5233



stone grey metallic 5215



Havana brown textured finish 5229



anthracite metallic 5204



Alternatively front profile end caps can be supplied in polished chrome

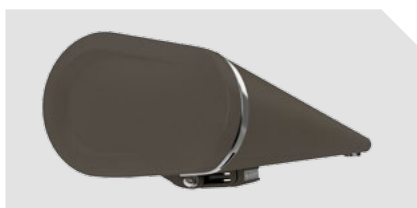

### Frame colours

		standard	optional
traffic white	RAL 9016	<input type="checkbox"/>	
metallic aluminium	RAL 9006	<input type="checkbox"/>	
grey brown, similar to	RAL 8019	<input type="checkbox"/>	
light ivory	RAL 1015	<input type="checkbox"/>	
anthracite metallic	5204	<input type="checkbox"/>	
stone grey metallic	5215	<input type="checkbox"/>	
off-white textured finish	5233	<input type="checkbox"/>	
Havana brown textured finish	5229	<input type="checkbox"/>	
non-standard powder-coated finish			







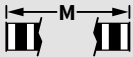
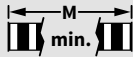

### Other end cap colour options

	standard	optional
polished chrome		<input type="checkbox"/>

Colours similar to those in the RAL chart. Colours may differ slightly from those depicted in both hue and finish.

- 01
- 02
- 03
- 04
- 05
- 06
- 07
- 08
- 09
- 10
- 11
- 12
- 13
- 14
- 15
- 16
- 17
- 18
- 19
- 20
- 21
- 22
- 23

### Dimensions and configuration options

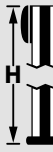
																		
		250	300	350	400	450	500	550	600	650	700 <sup>2)</sup>							
		187 250	251 300	301 350	351 400	401 450	451 500	501 550	551 600	601 650	651 700							
	150	4)												200	187	446	200	187
	200	4)												250	237	496	250	237
	250	-	4)											300	287	546	300	287
	300	-	-	4)						3)	3)			350	337	596	350	338
	350 <sup>1)</sup>	-	-	-	4)						2)			400	387	646	400	387
	400 <sup>1)2)</sup>	-	-	-	-	4)				-	-			450	437	696	450	437

dimensions in cm

 = 
 =  
 =  

- 1) a shadeplus / drop valance is not possible
- 2) awnings with 3 arms or a projection of 400 cm are only available with motor
- 3) with 3 folding arms, if fitted with a shadeplus / drop valance
- 4) please note the minimum widths!

Due to the compact awning construction and depending on the width and the projection, contact between cover and folding arms may occur during extension and retraction. This has no detrimental effect on the functionality and / or durability of the awning.

#### Operation / Drive

	standard	optional
manual operation	<input checked="" type="checkbox"/>	-
servo-assisted operation	-	<input checked="" type="checkbox"/>
hard-wired motor	-	<input checked="" type="checkbox"/>
io radio controls	-	<input checked="" type="checkbox"/>
silentec	-	<input checked="" type="checkbox"/> <sup>5)</sup>
radio-controlled motor (433 MHz)	-	<input checked="" type="checkbox"/>

5) in the case of awnings with 2 folding arms

#### Coupled units

	standard	optional
2 fields	-	<input checked="" type="checkbox"/> <sup>6)</sup>
3 fields	-	<input checked="" type="checkbox"/>
junction roller	-	<input checked="" type="checkbox"/> <sup>7)</sup>
one-piece cover	-	<input checked="" type="checkbox"/> <sup>8)</sup>



- 6) minimum widths see "Technical Information"
- 7) see overview "Bracket fixture range"
- 8) up to a maximum awning pitch of 15°, up to a maximum projection of 350 cm; without interior cover profile



#### Covers

	fabric range no.	standard	optional
sunsilk snc	324 .. / 328 .. / 369 ..	<input checked="" type="checkbox"/>	-
sunsilk perla FR	374 ..	-	<input checked="" type="checkbox"/>
sunvas	310 .. / 311 .. 313 .. — 315 ..	<input checked="" type="checkbox"/>	-
sunvas perla	370 ..	-	<input checked="" type="checkbox"/>

#### Shadeplus / Drop valance

	standard	optional
manual operation	<input checked="" type="checkbox"/>	-

 = motor
  = manual operation
 **M** = awning width

 = no. of folding arms
  = no. of bespoke arms
 **M min.** = minimum widths

 = no. of rolltex bearings
 **H** = projection

Miscellaneous

	standard	optional
bionic tendon	—	<input checked="" type="checkbox"/>
wall sealing profile	—	<input checked="" type="checkbox"/> <sup>1)</sup>
lighting (using the markilux spotlight)	—	<input checked="" type="checkbox"/>
insertable side blind	—	<input checked="" type="checkbox"/>
light and wind sensor	—	<input checked="" type="checkbox"/>
valance	—	<input checked="" type="checkbox"/>
infrared heater	—	<input checked="" type="checkbox"/>
vibrabox / radio control light sensor Sunis WireFree	—	<input checked="" type="checkbox"/>

1) up to a maximum awning pitch of 35°

Dimensions and tolerances

	width	projection
housing tolerances	+5 / -15 mm	±40 mm
awning cover width = awning width	-160 / -180 <sup>2)</sup> mm	
awning cover length = awning projection		+150 mm

2) for awnings with shadeplus / drop valance both for the awning **and** the shadeplus cover

Additional information

The width of the awning cover is always **less** than that of the awning. Please refer cover sizes in the case of coupled units and those with more than 2 arms to us.

Awning pitch range:

from 5° to 35° or 36° to 65° (to the horizontal).

Definition of projection:

Please consult the section “Technical Information”.

In the case of manual operation approximately **16 winding handle revolutions can be assumed per metre of awning projection.**

It takes approximately **12 seconds per metre** to extend the awning in the case of **motor-driven units.**

**Definition of shadeplus drop:** The shadeplus drop is measured from the bottom edge of the shadeplus profile to the bottom edge of the valance profile. Due to fabric thickness tolerances the actual drop may be shorter than the nominal drop by up to 5 cm. For the maximum shadeplus drops please consult the section “Technical Information”.

A shadeplus is not available with sunsilk perla FR, sunvas perla or PVC covers.

**Coupled folding-arm awnings** are available up to a **max. of 3 single units** side by side, however only with a maximum of 6 folding arms and **only operated by motor.**

A coupled unit is available with **junction roller.** Pattern repeat mismatches are possible in the case of junction roller covers. A junction roller may not fit when the projection is the maximum for the width of each awning. (see also the section on “Installation”, the arm separation table).

If coupled awnings are fitted into a **recess or reveal** the overall width of the coupled awning must be at least 6 cm less than the width of the opening to allow the awning to be coupled.

A radio-controlled motor in io technology is available (see “Optional Accessories”), but io control is not available for the spotlight.

01  
02  
03  
04  
**05**  
06  
07  
08  
09  
10  
11  
12  
13  
14  
15  
16  
17  
18  
19  
20  
21  
22  
23

### Fixtures, fittings and accessories

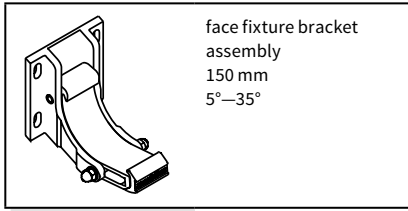

face fixture bracket assembly  
150 mm  
5°–35°

77921.

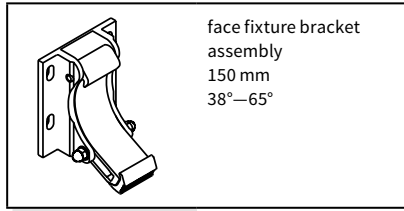

face fixture bracket assembly  
150 mm  
38°–65°

77936.

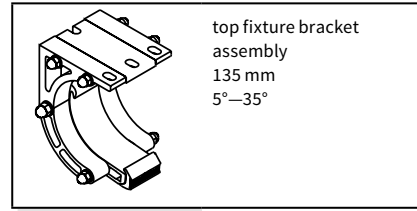

top fixture bracket assembly  
135 mm  
5°–35°

77937.

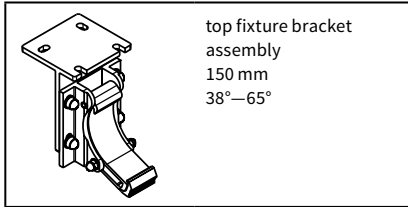

top fixture bracket assembly  
150 mm  
38°–65°

77938.

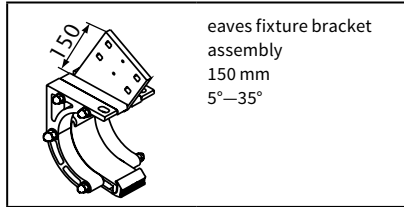

eaves fixture bracket assembly  
150 mm  
5°–35°

77939.

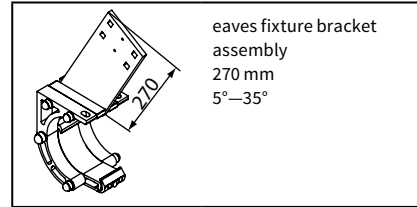

eaves fixture bracket assembly  
270 mm  
5°–35°

77940.

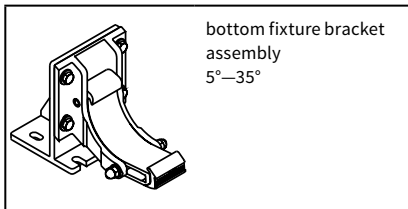

bottom fixture bracket assembly  
5°–35°

77941.

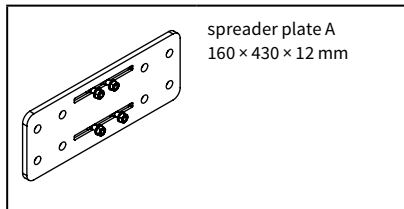

spreader plate A  
160 × 430 × 12 mm

75328.

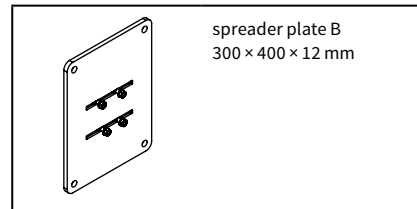

spreader plate B  
300 × 400 × 12 mm

75327.

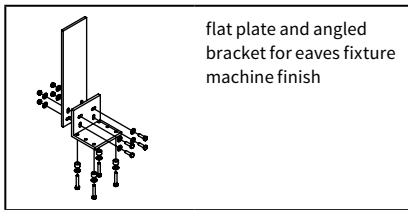

flat plate and angled bracket for eaves fixture machine finish

741290

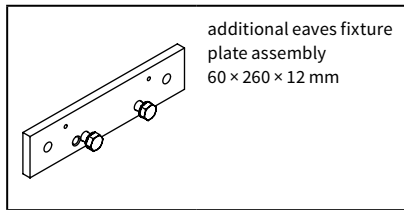

additional eaves fixture plate assembly  
60 × 260 × 12 mm

75383.

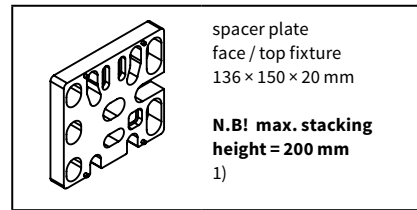

spacer plate face / top fixture  
136 × 150 × 20 mm

**N.B! max. stacking height = 200 mm**  
1)

716331

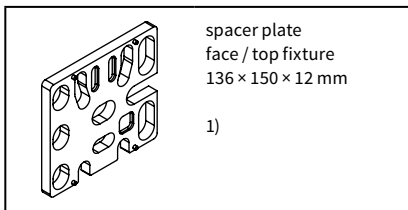

spacer plate face / top fixture  
136 × 150 × 12 mm

1)

71644.

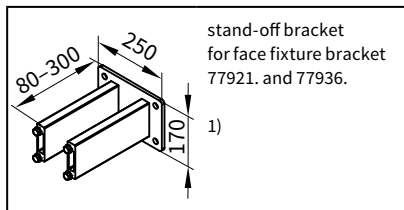

stand-off bracket for face fixture bracket 77921. and 77936.

1)

77969.

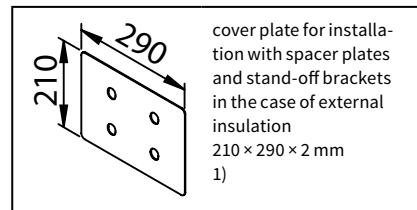

cover plate for installation with spacer plates and stand-off brackets in the case of external insulation  
210 × 290 × 2 mm

1)

71841.

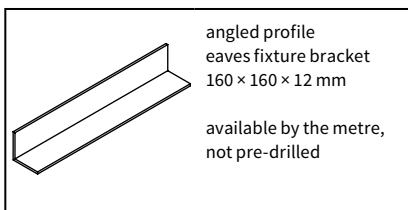

angled profile eaves fixture bracket  
160 × 160 × 12 mm

available by the metre, not pre-drilled

701809

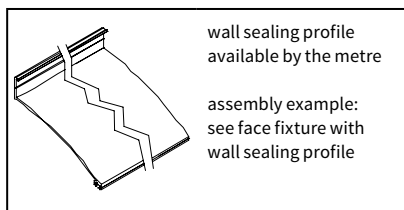

wall sealing profile available by the metre

assembly example: see face fixture with wall sealing profile

77780.

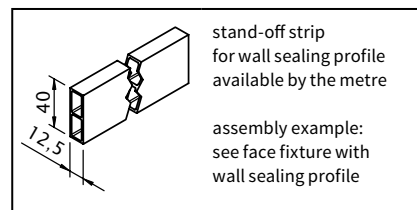

stand-off strip for wall sealing profile available by the metre

assembly example: see face fixture with wall sealing profile

751971

1) please refer to the section "Technical Information"

. = insert RAL colour code no

### Fixtures, fittings and accessories

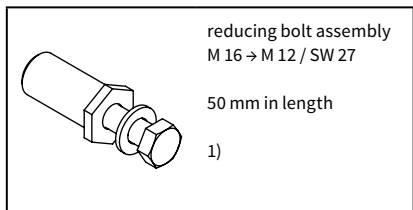

753891

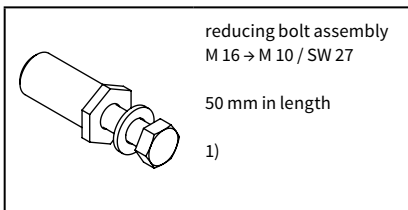

754921

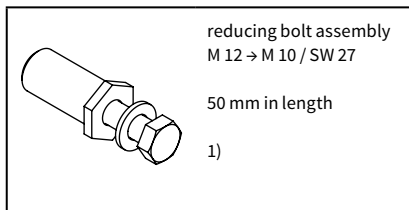

754911

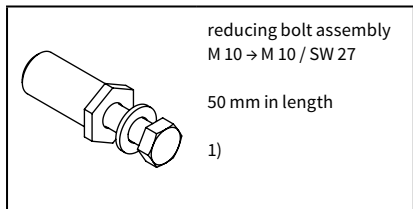

754901

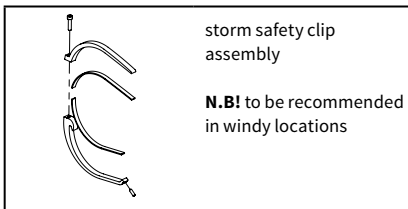

76903.

. = insert RAL colour code no

1) please refer to the section "Technical Information"

- 01
- 02
- 03
- 04
- 05
- 06
- 07
- 08
- 09
- 10
- 11
- 12
- 13
- 14
- 15
- 16
- 17
- 18
- 19
- 20
- 21
- 22
- 23



## Face fixture

Pull-out force [N=Newton] per upper fixing point according to EN 13561, wind resistance class 2

### Compression-proof substrate

M [cm]

250	300	350	400	450	500	550	600	650	700
-----	-----	-----	-----	-----	-----	-----	-----	-----	-----

H [cm]

FB [N]

H [cm]	250	300	350	400	450	500	550	600	650	700
150	505	583	661	739	816	894	972	1050	1127	935
200	834	957	1079	1202	1324	1447	1569	1692	1815	1603
250	—	1364	1541	1717	1894	2071	2247	2424	2937	2622
300	—	—	2079	2319	2559	2799	3447	3726	4004	3597
350	—	—	—	3101	3415	4231	4596	4961	4653	4929
400	—	—	—	—	4874	5337	5801	—	—	6233

### Non compression-proof substrate

M [cm]

250	300	350	400	450	500	550	600	650	700
-----	-----	-----	-----	-----	-----	-----	-----	-----	-----

FB [N]

H [cm]	250	300	350	400	450	500	550	600	650	700
150	578	667	756	845	934	1023	1112	1201	1290	1070
200	955	1095	1235	1376	1516	1656	1796	1936	2077	1834
250	—	1561	1763	1965	2167	2370	2572	2774	3361	3001
300	—	—	2379	2654	2929	3204	3945	4264	4582	4117
350	—	—	—	3549	3908	4842	5260	5678	5326	5642
400	—	—	—	—	5578	6108	6638	—	—	7133

HT   BHT	2   150 mm	3   150 mm	4   150 mm
----------	------------	------------	------------

HT   BHT	2   150 mm	3   150 mm	4   150 mm
----------	------------	------------	------------

BM	8	12	16
----	---	----	----

BM	8	12	16
----	---	----	----

The pull-out force refers to the vertical centre to centre measurement between the fixture points of **90 mm**. If this measurement is reduced to the minimum, the pull-out force increases by **2%** in the case of **compression-proof substrates** and by **19%** in the case of **non compression-proof substrates**.

- M = awning width
- H = projection
- FB = pull-out force per fixing point
- HT | BHT = bracket quantity | width
- BM = no. of fixing points
- WA = wall sealing profile

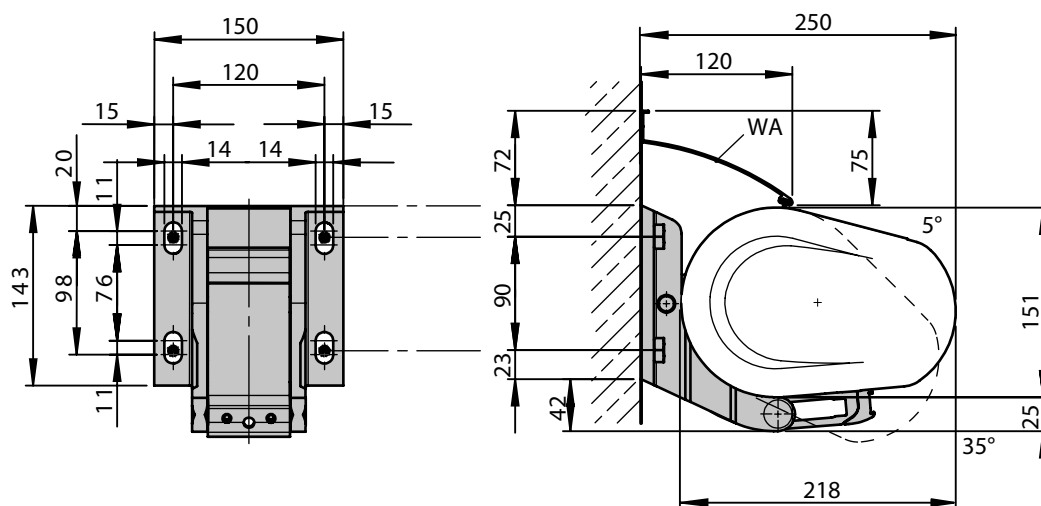

dimensions in mm



# Face fixture with spreader plate A

Pull-out force [N=Newton] per upper fixing point according to EN 13561, wind resistance class 2

Compression-proof substrate											Non compression-proof substrate										
M [cm]											M [cm]										
H [cm]											H [cm]										
FB [N]											FB [N]										
250	300	350	400	450	500	550	600	650	700		250	300	350	400	450	500	550	600	650	700	
150	244	282	319	357	394	432	469	507	544	428	347	400	453	507	560	613	667	720	773	608	
200	402	461	520	579	638	697	756	815	874	725	571	655	739	822	906	990	1074	1158	1241	1031	
250	-	656	741	825	910	995	1080	1165	1412	1195	-	932	1052	1173	1294	1414	1535	1655	2006	1699	
300	-	-	998	1113	1229	1344	1655	1789	1922	1641	-	-	1418	1582	1746	1910	2352	2542	2732	2332	
350	-	-	-	1488	1638	2030	2205	2380	2100	2233	-	-	-	2114	2328	2884	3133	3382	2985	3174	
400	-	-	-	-	2337	2559	2781	-	-	2827	-	-	-	-	3320	3636	3952	-	-	4017	
HT   BHT	2   150 mm			3   150 mm			4   150 mm				2   150 mm			3   150 mm			4   150 mm				
BP	2			2			3				2			2			3				
DP	-			1			1				-			1			1				
BM	16			12			28				16			20			28				

The pull-out force refers to the vertical centre to centre measurement between the fixing points of 76 mm. In the case of spreader plates a washer conforming to DIN 9021 must be used.

- M = awning width
- H = projection
- FB = pull-out force per fixing point
- HT | BHT = bracket quantity | width
- BP = no. of spreader plates
- DP = no. of spacer plates
- BM = no. of fixing points
- WA = wall sealing profile
- 75197. = stand-off strip for wall sealing profile

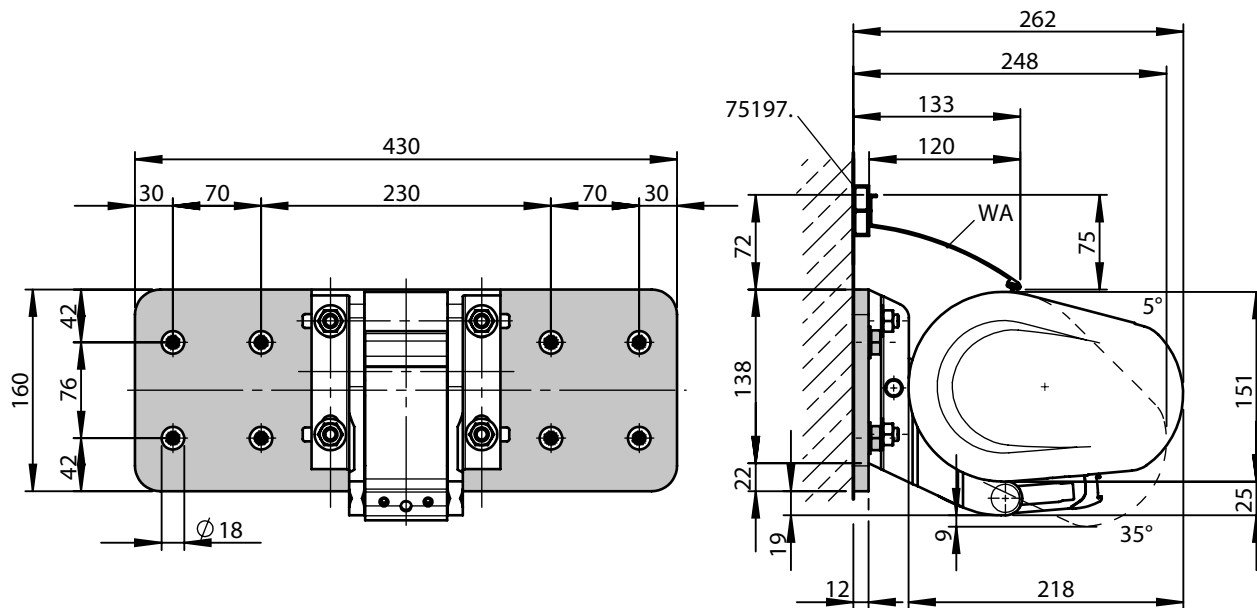

dimensions in mm

### Face fixture with spreader plate B

Pull-out force [N=Newton] per upper fixing point according to EN 13561, wind resistance class 2

**compression-proof** substrate

M [cm]

250	300	350	400	450	500	550	600	650	700
-----	-----	-----	-----	-----	-----	-----	-----	-----	-----

H [cm]

FB [N]

150	144	167	189	211	233	255	278	300	322	253
200	238	273	308	342	377	412	447	482	517	429
250	-	388	438	488	538	589	639	689	835	707
300	-	-	591	659	727	795	979	1059	1138	971
350	-	-	-	880	969	1201	1305	1408	1243	1322
400	-	-	-	-	1383	1514	1646	-	-	1673

**non compression-proof** substrate

M [cm]

250	300	350	400	450	500	550	600	650	700
-----	-----	-----	-----	-----	-----	-----	-----	-----	-----

FB [N]

151	174	197	220	243	266	289	313	336	264
248	284	321	357	394	430	466	503	539	448
-	405	457	509	562	614	667	719	871	738
-	-	616	687	758	829	1021	1104	1186	1013
-	-	-	918	1011	1253	1361	1469	1296	1378
-	-	-	-	1442	1579	1716	-	-	1744

HT   BHT	2   150 mm	3   150 mm	4   150 mm
----------	------------	------------	------------

2   150 mm	3   150 mm	4   150 mm
------------	------------	------------

BP	2	2	3
DP	-	1	1
BM	8	12	16

2	2	3
-	1	1
8	12	16

The pull-out force refers to the vertical centre to centre measurement between the fixing points of **350 mm**. In the case of spreader plates a washer conforming to DIN 9021 must be used.

- M = awning width
- H = projection
- FB = pull-out force per fixing point
- HT | BHT = bracket quantity | width
- BP = no. of spreader plates
- DP = no. of spacer plates
- BM = no. of fixing points
- 75197. = stand-off strip for wall sealing profile

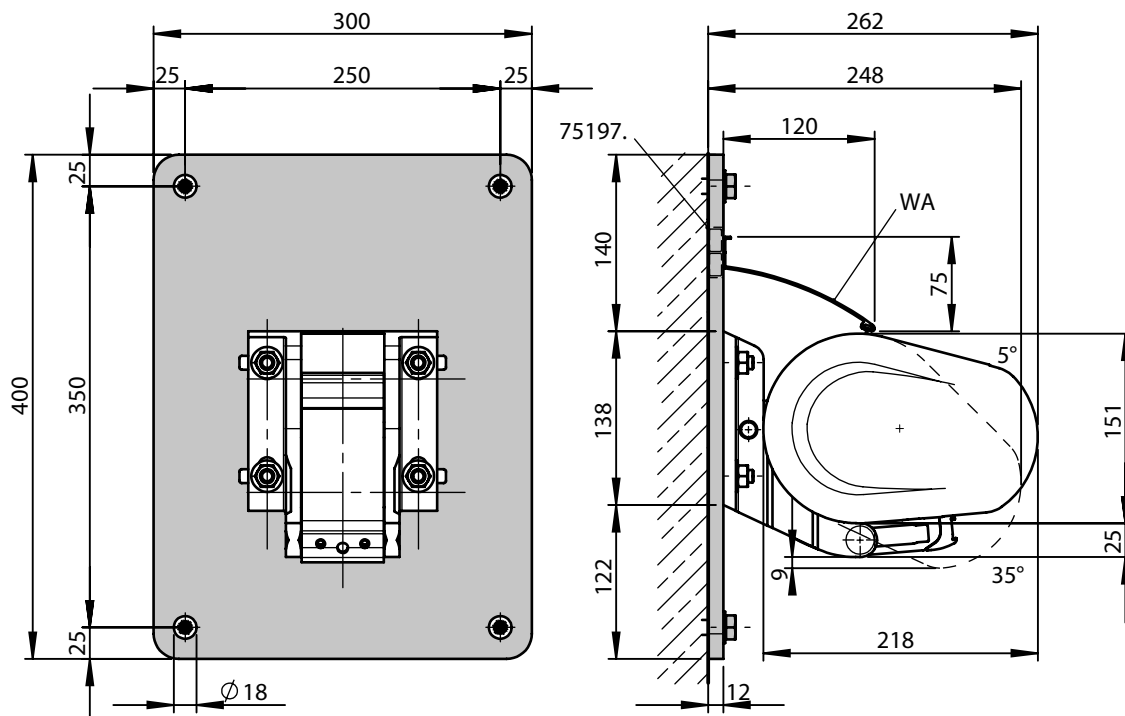

dimensions in mm

### Face fixture using stand-off brackets

Pull-out force [N=Newton] per upper fixing point according to EN 13561, wind resistance class 2

compression-proof substrate											non compression-proof substrate										
M [cm]											M [cm]										
H [cm]											FB [N]										
250	300	350	400	450	500	550	600	650	700		250	300	350	400	450	500	550	600	650	700	
150	506	583	659	736	813	890	966	1043	1120	881	569	656	742	828	915	1001	1087	1174	1260	991	
200	793	909	1024	1139	1254	1369	1485	1600	1715	1424	893	1022	1152	1281	1411	1541	1670	1800	1929	1602	
250	-	1250	1411	1572	1733	1893	2054	2215	2691	2278	-	1406	1587	1768	1949	2130	2311	2492	3027	2563	
300	-	-	1857	2070	2284	2497	3082	3331	3579	3054	-	-	2089	2329	2569	2810	3467	3747	4026	3436	
350	-	-	-	2719	2992	3714	4033	4353	3841	4084	-	-	-	3059	3366	4178	4538	4897	4321	4595	
400	-	-	-	-	4215	4615	5015	-	-	5097	-	-	-	-	4742	5192	5642	-	-	5734	
HT   BHT	2   150 mm			3   150 mm			4   150 mm				2   150 mm			3   150 mm			4   150 mm				
DH 77969.	2			3			4				2			3			4				
BM	8			12			16				8			12			16				

The pull-out force refers to the vertical centre to centre measurement between the fixing points of **120 mm**. In the case of stand-off brackets a washer conforming to DIN 9021 must be used.

- M = awning width
- H = projection
- FB = pull-out force per fixing point
- HT | BHT = bracket quantity | width
- BM = no. of fixing points
- DH = no. of stand-off brackets
- 75970. = stand-off brackets for face fixture brackets 77921. and 77936.

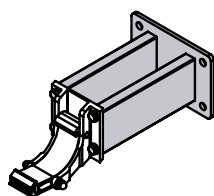

77969.

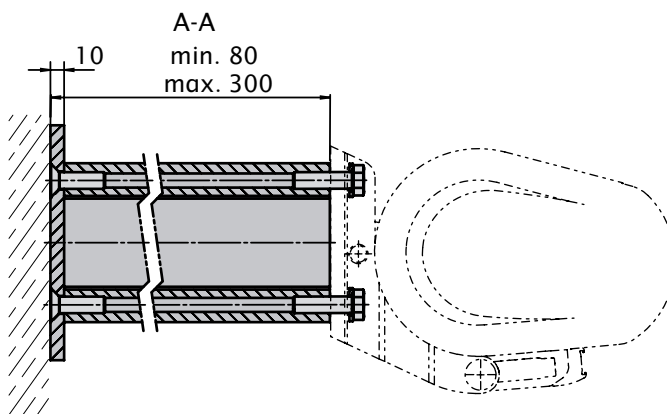
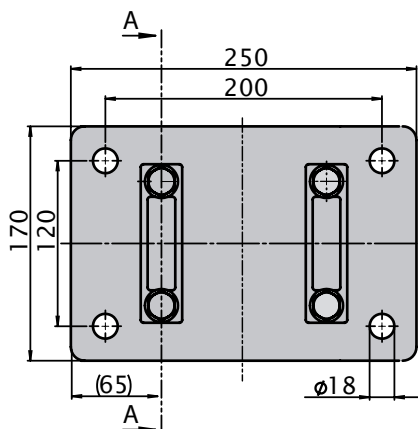

dimensions in mm

01  
02  
03  
04  
**05**  
06  
07  
08  
09  
10  
11  
12  
13  
14  
15  
16  
17  
18  
19  
20  
21  
22  
23

### Face fixture with shadeplus / drop valance

Pull-out force [N=Newton] per upper fixing point according to EN 13561, wind resistance class 2

**compression-proof** substrate  
M [cm]

**non compression-proof** substrate  
M [cm]

H [cm]	compression-proof substrate										non compression-proof substrate									
	M [cm]										M [cm]									
	250	300	350	400	450	500	550	600	650	700	250	300	350	400	450	500	550	600	650	700
150	818	958	1098	1239	1379	1519	1659	1800	1940	1579	936	1097	1257	1418	1578	1739	1899	2060	2220	1807
200	1251	1457	1663	1869	2074	2280	2486	2692	2898	2510	1432	1667	1903	2139	2374	2610	2845	3081	3316	2873
250	-	1989	2270	2551	2831	3112	3393	3674	4291	3777	-	2276	2598	2919	3240	3562	3883	4205	4911	4322
300	-	-	2954	3319	3684	4049	4822	-	-	4994	-	-	3380	3798	4216	4634	5519	-	-	-
HT   BHT	2   150 mm			3   150 mm			4   150 mm				2   150 mm			3   150 mm			4   150 mm			
BM	8			12			16				8			12			16			

The pull-out force refers to the vertical centre to centre measurement between the fixture points of **90 mm**. If this measurement is reduced to the minimum, the pull-out force increases by **2%** in the case of **compression-proof substrates** and by **19%** in the case of **non compression-proof substrates**.

- M = awning width
- H = projection
- FB = pull-out force per fixing point
- HT | BHT = bracket quantity | width
- BM = no. of fixing points
- WA = wall sealing profile

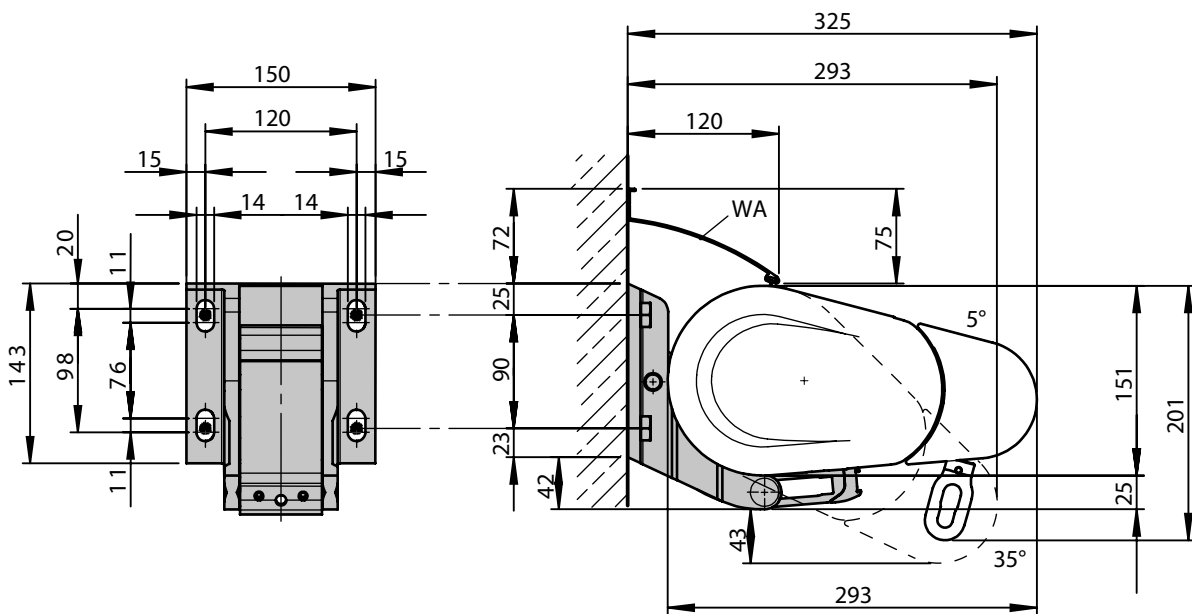

dimensions in mm

# Face fixture with shadeplus / drop valance and spreader plate A

Pull-out force [N=Newton] per upper fixing point according to EN 13561, wind resistance class 2

compression-proof substrate										non compression-proof substrate										
M [cm]										M [cm]										
H [cm]										FB [N]										
250	300	350	400	450	500	550	600	650	700	250	300	350	400	450	500	550	600	650	700	
150	394	462	529	597	664	732	800	867	935	738	560	656	752	848	944	1040	1136	1232	1328	1048
200	602	701	800	899	997	1096	1195	1294	1393	1161	855	996	1136	1277	1417	1558	1699	1839	1980	1650
250	-	955	1090	1225	1360	1494	1629	1764	2060	1749	-	1357	1549	1740	1932	2123	2315	2507	2928	2485
300	-	-	1417	1592	1767	1942	2313	-	-	2309	-	-	2014	2262	2511	2760	3288	-	-	3282
HT   BHT	2   150 mm			3   150 mm			4   150 mm			2   150 mm			3   150 mm			4   150 mm				
BP	2			2			3			2			2			3				
DP	-			1			1			-			1			1				
BM	16			20			28			16			20			28				

The pull-out force refers to the vertical centre to centre measurement between the fixing points of **76 mm**. In the case of spreader plates a washer conforming to DIN 9021 must be used.

- M = awning width
- H = projection
- FB = pull-out force per fixing point
- HT | BHT = bracket quantity | width
- BP = no. of spreader plates
- BM = no. of fixing points
- DP = no. of spacer plates
- WA = wall sealing profile
- 75197. = stand-off strip for wall sealing profile

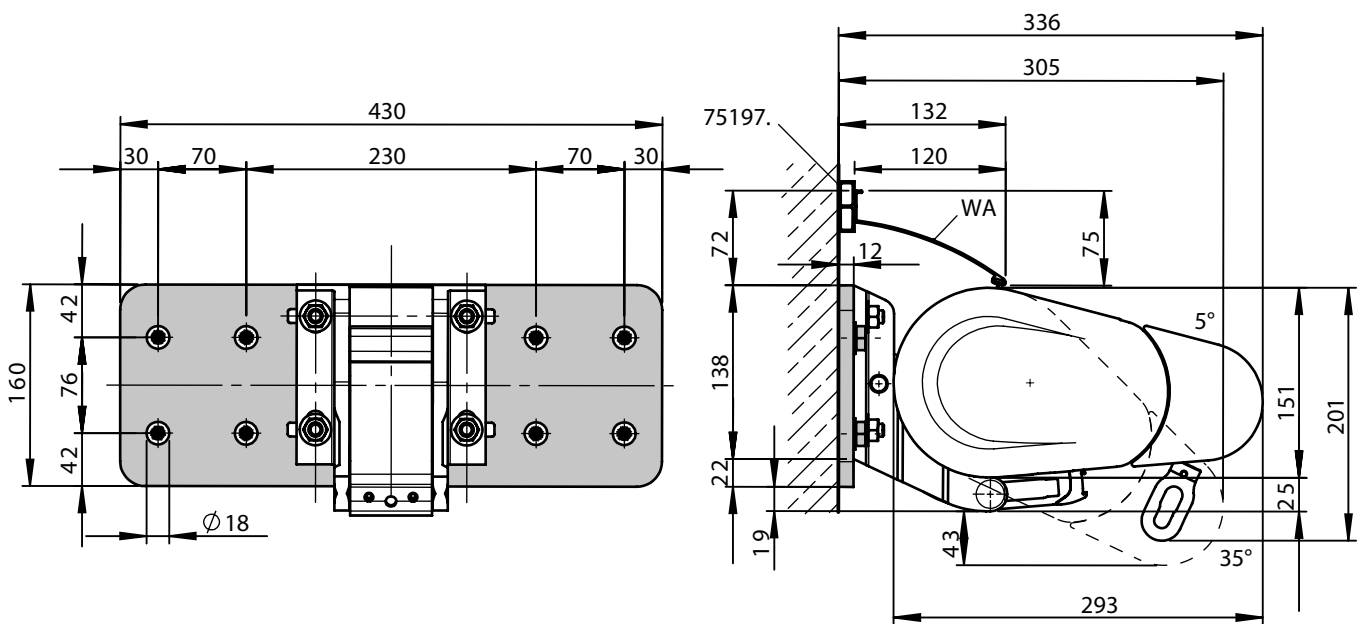

dimensions in mm

- 01
- 02
- 03
- 04
- 05
- 06
- 07
- 08
- 09
- 10
- 11
- 12
- 13
- 14
- 15
- 16
- 17
- 18
- 19
- 20
- 21
- 22
- 23

### Face fixture with shadeplus / drop valance and spreader plate B

Pull-out force [N=Newton] per upper fixing point according to EN 13561, wind resistance class 2

**compression-proof** substrate

**non compression-proof** substrate

		M [cm]									
		250	300	350	400	450	500	550	600	650	700
<b>H [cm]</b>	<b>150</b>	233	273	313	353	393	433	473	513	553	437
	<b>200</b>	356	415	473	532	590	649	707	766	824	687
	<b>250</b>	-	565	645	725	805	884	964	1044	1219	1035
	<b>300</b>	-	-	839	942	1046	1149	1369	-	-	1367
	<b>HT   BHT</b>	2   150 mm		3   150 mm			4   150 mm				
<b>BP</b>	2		2			3					
<b>DP</b>	-		1			1					
<b>BM</b>	8		12			16					

		M [cm]									
		250	300	350	400	450	500	550	600	650	700
<b>H [cm]</b>	<b>150</b>	243	285	327	368	410	452	493	535	577	455
	<b>200</b>	371	432	493	555	616	677	738	799	860	716
	<b>250</b>	-	589	673	756	839	922	1005	1089	1272	1079
	<b>300</b>	-	-	874	983	1091	1199	1428	-	-	1425
	<b>HT   BHT</b>	2   150 mm		3   150 mm			4   150 mm				
<b>BP</b>	2		2			3					
<b>DP</b>	-		1			1					
<b>BM</b>	8		12			16					

The pull-out force refers to the vertical centre to centre measurement between the fixing points of **350 mm**. In the case of spreader plates a washer conforming to DIN 9021 must be used.

- M = awning width
- H = projection
- FB = pull-out force per fixing point
- HT | BHT = bracket quantity | width
- BP = no. of spreader plates
- DP = no. of spacer plates
- BM = no. of fixing points
- 75197. = stand-off strip for wall sealing profile

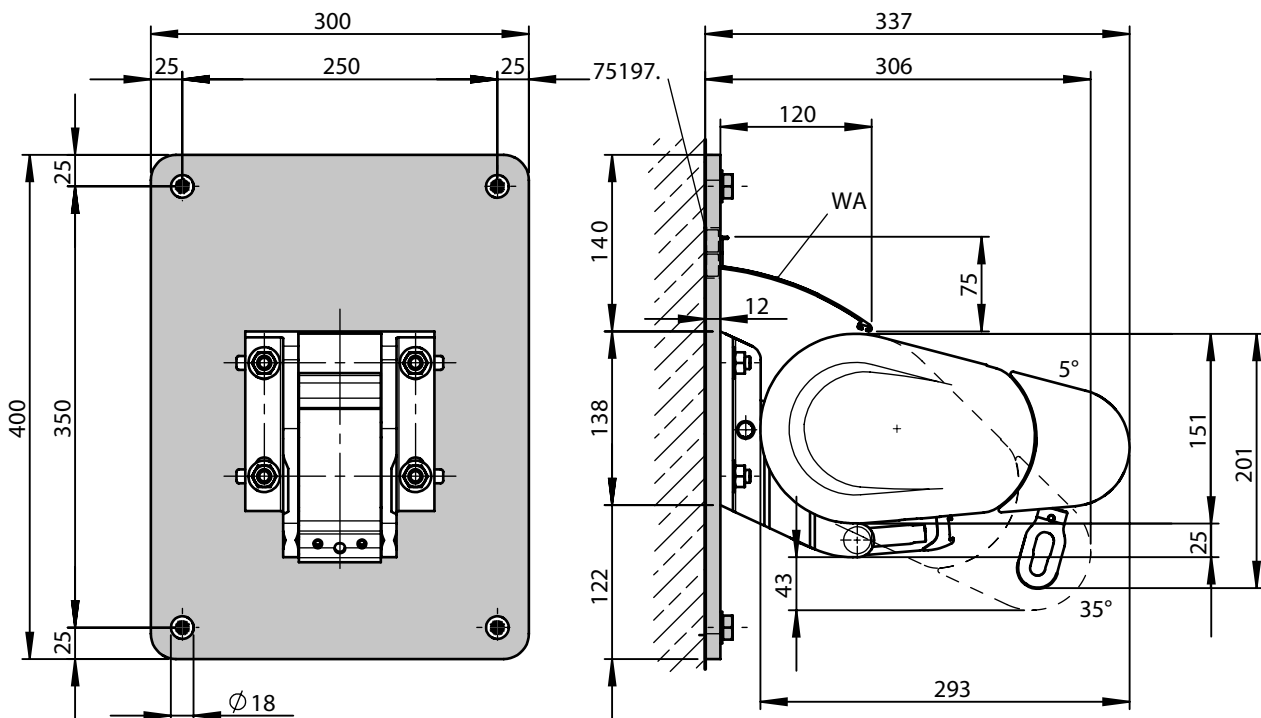

dimensions in mm

### Face fixture with shadeplus / drop valance and stand-off brackets

Pull-out force [N=Newton] per upper fixing point according to EN 13561, wind resistance class 2

compression-proof substrate											non compression-proof substrate										
M [cm]											M [cm]										
H [cm]											FB [N]										
250	300	350	400	450	500	550	600	650	700		250	300	350	400	450	500	550	600	650	700	
150	506	583	659	736	813	890	966	1043	1120	881	569	656	742	828	915	1001	1087	1174	1260	991	
200	793	909	1024	1139	1254	1369	1485	1600	1715	1424	893	1022	1152	1281	1411	1541	1670	1800	1929	1602	
250	-	1250	1411	1572	1733	1893	2054	2215	2691	2278	-	1406	1587	1768	1949	2130	2311	2492	3027	2563	
300	-	-	1857	2070	2284	2497	3082	3331	3579	3054	-	-	2089	2329	2569	2810	3467	3747	4026	3436	
350	-	-	-	2719	2992	3714	4033	4353	3841	4084	-	-	-	3059	3366	4178	4538	4897	4321	4595	
400	-	-	-	-	4215	4615	5015	-	-	5097	-	-	-	-	4742	5192	5642	-	-	5734	
HT   BHT	2   150 mm			3   150 mm			4   150 mm				2   150 mm			3   150 mm			4   150 mm				
DH 77969.	2			3			4				2			3			4				
BM	8			12			16				8			12			16				

The pull-out force refers to the vertical centre to centre measurement between the fixing points of **120 mm**. In the case of stand-off brackets a washer conforming to DIN 9021 must be used.

- M = awning width
- H = projection
- FB = pull-out force per fixing point
- HT | BHT = bracket quantity | width
- BM = no. of fixing points
- DH = no. of stand-off brackets
- 77969. = stand-off brackets for face fixture brackets 74921. and 74936.

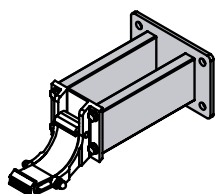

77969.

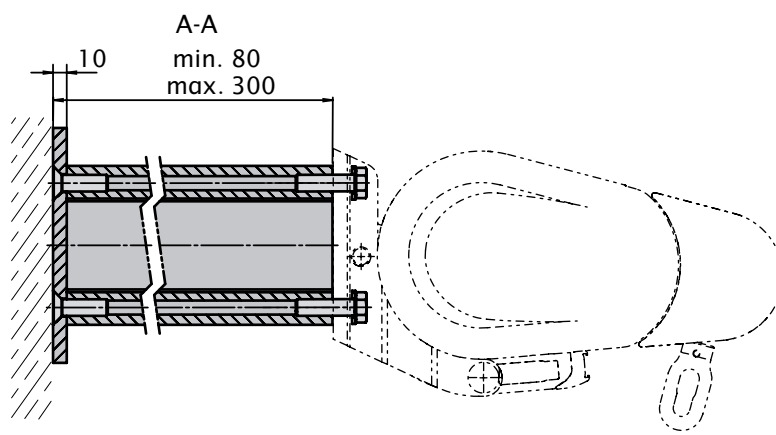
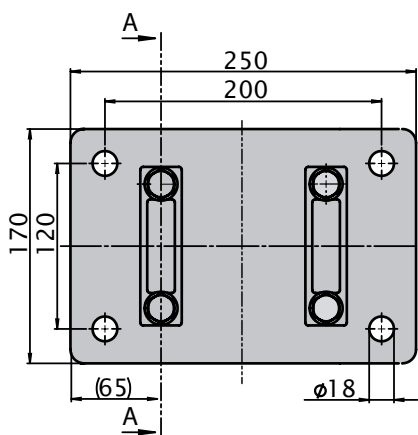

dimensions in mm

01  
02  
03  
04  
**05**  
06  
07  
08  
09  
10  
11  
12  
13  
14  
15  
16  
17  
18  
19  
20  
21  
22  
23



## Top fixture

Pull-out force [N=Newton] per upper fixing point according to EN 13561, wind resistance class 2

### compression-proof substrate

M [cm]

250	300	350	400	450	500	550	600	650	700
-----	-----	-----	-----	-----	-----	-----	-----	-----	-----

H [cm]

FB [N]

H [cm]	250	300	350	400	450	500	550	600	650	700
150	463	537	611	685	759	833	908	982	1056	916
200	724	833	943	1052	1162	1271	1381	1491	1600	1445
250	-	1156	1308	1461	1613	1766	1981	2070	2489	2252
300	-	-	1734	1937	2140	2343	2869	3102	3335	3025
350	-	-	-	2557	2818	3477	3779	4081	3849	4081
400	-	-	-	-	3974	4354	4733	-	-	5114

### non compression-proof substrate

M [cm]

250	300	350	400	450	500	550	600	650	700
-----	-----	-----	-----	-----	-----	-----	-----	-----	-----

FB [N]

H [cm]	250	300	350	400	450	500	550	600	650	700
150	479	555	632	709	785	862	938	1015	1091	945
200	750	864	977	1090	1204	1317	1431	1544	1658	1496
250	-	1199	1357	1515	1673	1831	1989	2147	2582	2335
300	-	-	1800	2011	2221	2432	2978	3220	3462	3139
350	-	-	-	2656	2926	3611	3925	4238	3997	4237
400	-	-	-	-	4129	4523	4917	-	-	5311

HT   BHT	2   135 mm	3   135 mm	4   135 mm
----------	------------	------------	------------

HT   BHT	2   135 mm	3   135 mm	4   135 mm
----------	------------	------------	------------

BM	6	9	12
----	---	---	----

BM	6	9	12
----	---	---	----

The pull-out force refers to the horizontal centre to centre measurement between the fixture points of **125 mm**.

- M = awning width
- H = projection
- FB = pull-out force per fixing point
- HT | BHT = bracket quantity | width
- BM = no. of fixing points

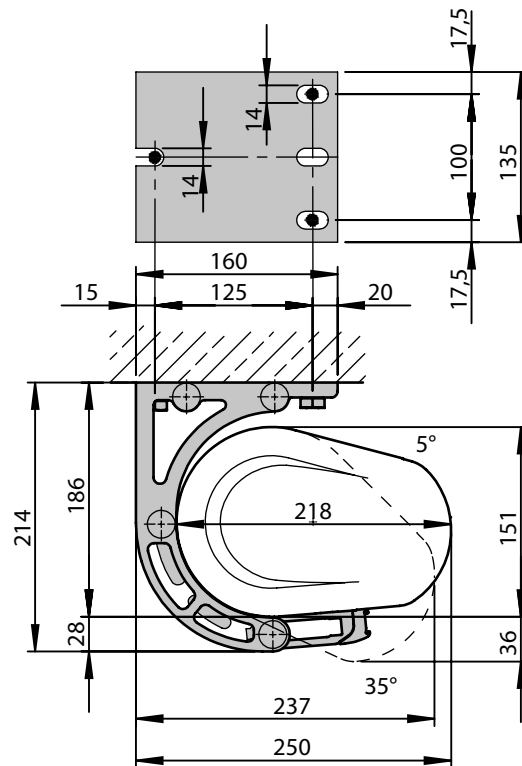

dimensions in mm

### Top fixture with shadeplus / drop valance

Pull-out force [N=Newton] per upper fixing point according to EN 13561, wind resistance class 2

compression-proof substrate											non compression-proof substrate										
M [cm]											M [cm]										
H [cm]											H [cm]										
FB [N]											FB [N]										
250	300	350	400	450	500	550	600	650	700	250	300	350	400	450	500	550	600	650	700		
150	711	834	958	1081	1205	1329	1452	1579	1699	1426	736	865	993	1121	1249	1377	1505	1633	1761	1476	
200	1054	1229	1405	1581	1756	1932	2107	2283	2459	2164	1093	1276	1458	1640	1822	2004	2186	2368	2550	2244	
250	-	1651	1886	2121	2356	2591	2826	3061	3562	3167	-	1714	1958	2202	2446	2690	2933	3177	3698	3287	
300	-	-	2428	2730	3031	3333	3958	-	-	4132	-	-	2521	2835	3148	3462	4111	-	-	4290	
HT   BHT	2   135 mm			3   135 mm			4   135 mm			2   135 mm			3   135 mm			4   135 mm					
BM	6			9			12			6			9			12					

The pull-out force refers to the horizontal centre to centre measurement between the fixture points of 125 mm.

- M = awning width
- H = projection
- FB = pull-out force per fixing point
- HT | BHT = bracket quantity | width
- BM = no. of fixing points

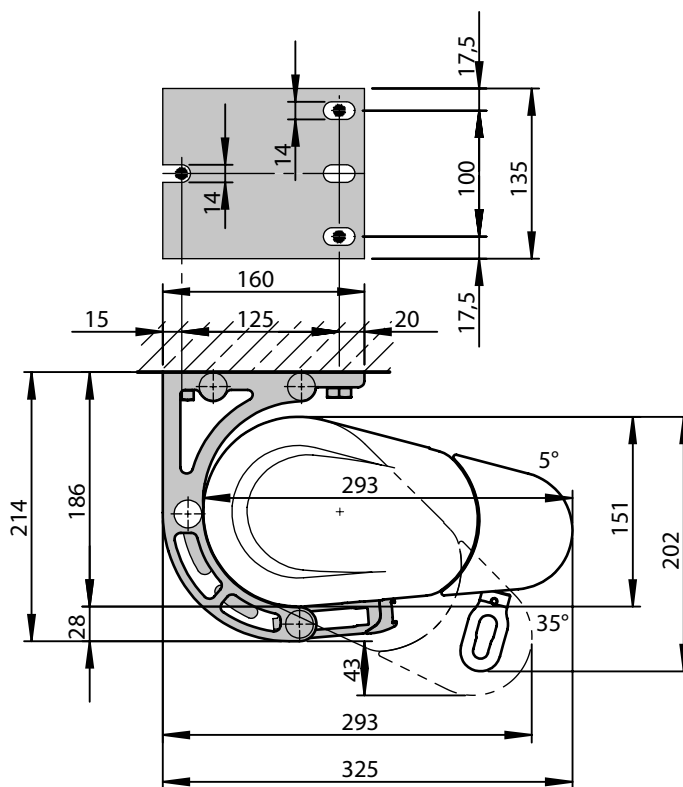

dimensions in mm

- 01
- 02
- 03
- 04
- 05
- 06
- 07
- 08
- 09
- 10
- 11
- 12
- 13
- 14
- 15
- 16
- 17
- 18
- 19
- 20
- 21
- 22
- 23

### Eaves fixture

Torque [Nm = Newton metres] for the fixture bracket in the immediate vicinity of the arm, shear force [N = Newton] per fixing point according to EN 13561, wind resistance class 2

H [cm]	Torque M [cm]										Shear force M [cm]									
	250	300	350	400	450	500	550	600	650	700	250	300	350	400	450	500	550	600	650	700
	FB [N]										FB [N]									
150	104	120	136	152	168	184	200	216	232	193	1282	1485	1688	1891	2094	2297	2499	2702	2905	2490
200	172	197	222	248	273	298	323	349	374	330	2035	2340	2646	2951	3257	3562	3867	4173	4478	4018
250	-	281	317	354	390	427	463	499	605	540	-	3272	3701	4131	4560	4989	5419	5848	7046	6351
300	-	-	428	478	527	577	710	767	825	741	-	-	4933	5508	6082	6657	8165	8828	9490	8584
350	-	-	-	639	703	872	947	1022	959	1015	-	-	-	7299	8040	9934	10795	11655	10976	11633
400	-	-	-	-	1004	1099	1195	-	-	1284	-	-	-	-	11381	12466	13552	-	-	14617
HT	2			3				4			2			3				4		
BM	8			12				16			8			12				16		

The shear force is calculated on the basis of 2 fixing points per bracket, because – depending on the roof pitch – it cannot be guaranteed that 4 fixing points per bracket can be used.

- M = awning width
- H = projection
- Md = torque value for the bracket in the immediate vicinity of the arm
- HT = no. of brackets
- FS = shear force
- BM = no. of fixing points

eaves fixture bracket 5° to 35°

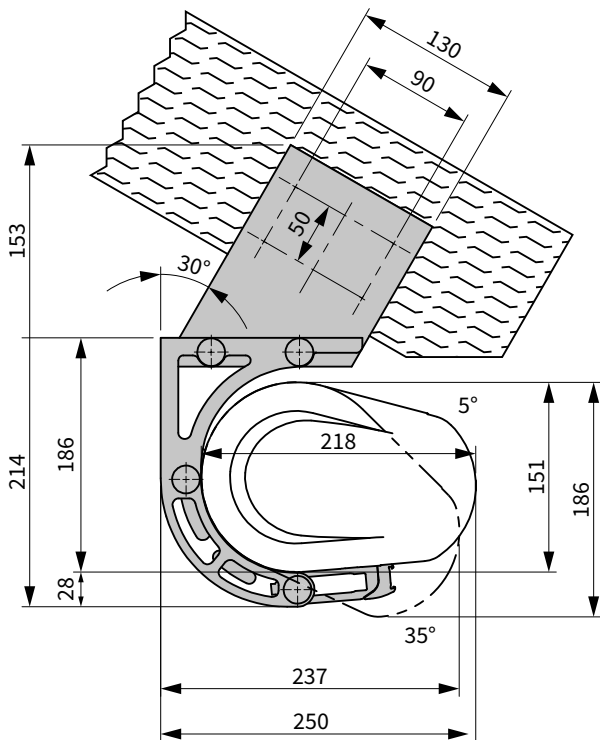

eaves fixture bracket 270 mm

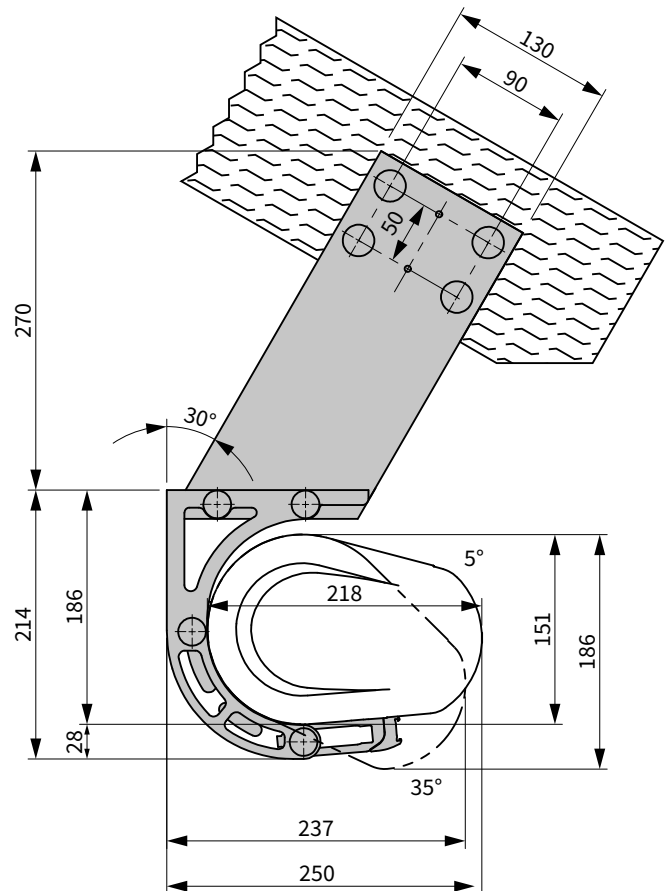

dimensions in mm

### Eaves fixture with additional spreader / backing plate

Torque [Nm = Newton metres] for the fixture bracket in the immediate vicinity of the arm, shear force [N = Newton] per fixing point according to EN 13561, wind resistance class 2

H [cm]	Torque M [cm]										Shear force M [cm]									
	250	300	350	400	450	500	550	600	650	700	250	300	350	400	450	500	550	600	650	700
	FB [N]										FB [N]									
150	104	120	136	152	168	184	200	216	232	193	646	751	856	961	1066	1171	1276	1381	1486	1313
200	172	197	222	248	273	298	323	349	374	330	984	1136	1287	1438	1589	1740	1892	2043	2194	2001
250	-	281	317	354	390	427	463	499	605	540	-	1555	1762	1969	2176	2383	2590	2797	3350	3050
300	-	-	428	478	527	577	710	767	825	741	-	-	2316	2588	2861	3133	3826	4137	4449	4055
350	-	-	-	639	703	872	947	1022	959	1015	-	-	-	3394	3742	4608	5009	5410	5118	5427
400	-	-	-	-	1004	1099	1195	-	-	1284	-	-	-	-	5245	5747	6250	-	-	6770
HT	2			3			4				2			3			4			
BM	4			6			8				4			6			8			

By using the additional spreader / backing plate, the shear force is reduced in comparison with conventional eaves fixture.

- M = awning width
- H = projection
- Md = torque value for the bracket in the immediate vicinity of the arm
- HT = no. of brackets
- FS = shear force
- BM = no. of fixing points

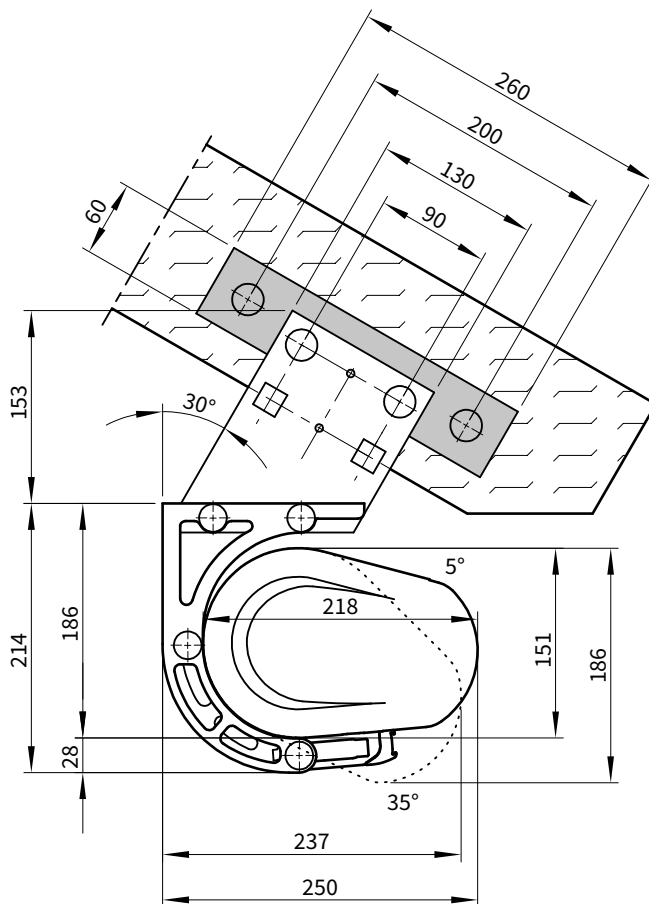

dimensions in mm

- 01
- 02
- 03
- 04
- 05
- 06
- 07
- 08
- 09
- 10
- 11
- 12
- 13
- 14
- 15
- 16
- 17
- 18
- 19
- 20
- 21
- 22
- 23

**Bottom fixture**

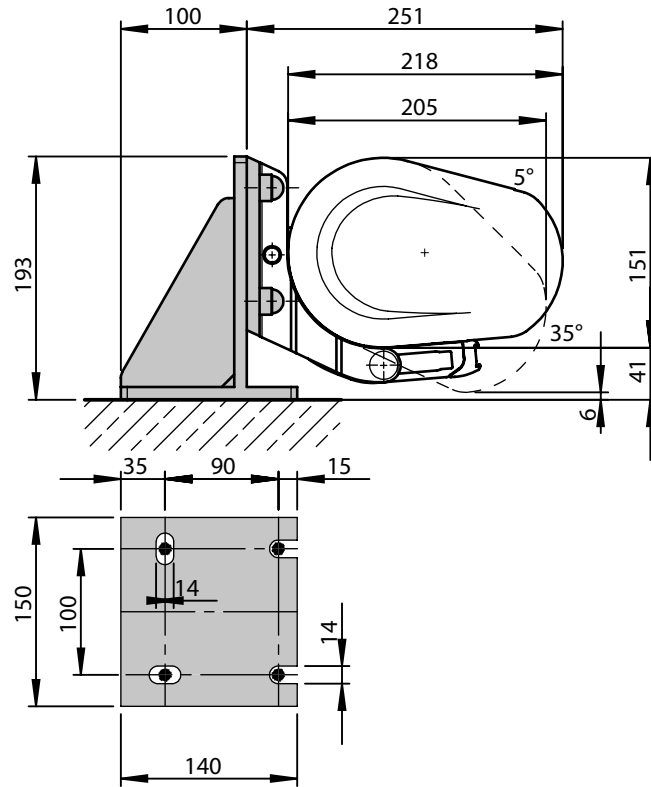

dimensions in mm

**Face fixture dimensions at pitches of 38° to 65°**

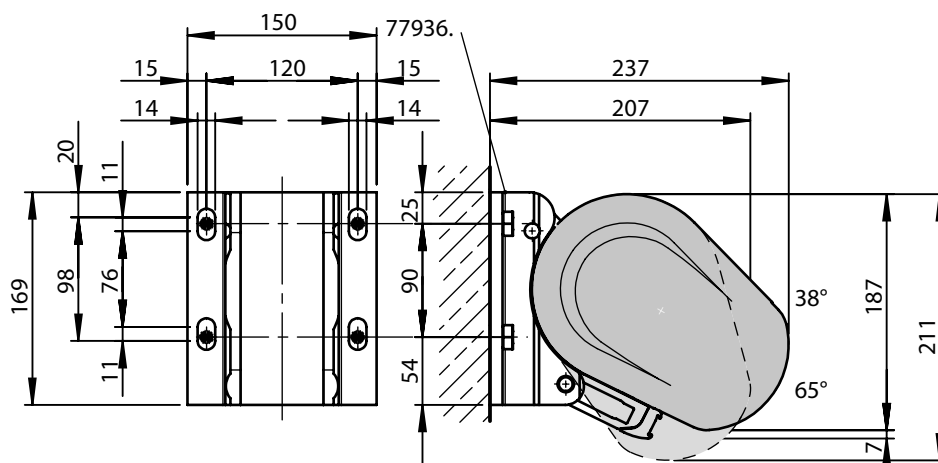

dimensions in mm

Top fixture dimensions at pitches of 38° to 65°

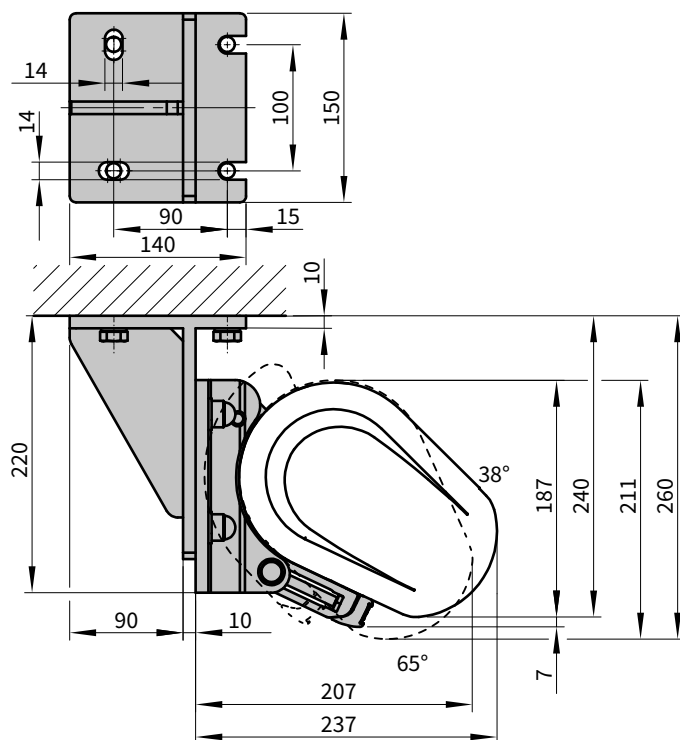

dimensions in mm

Face fixture with manual operation

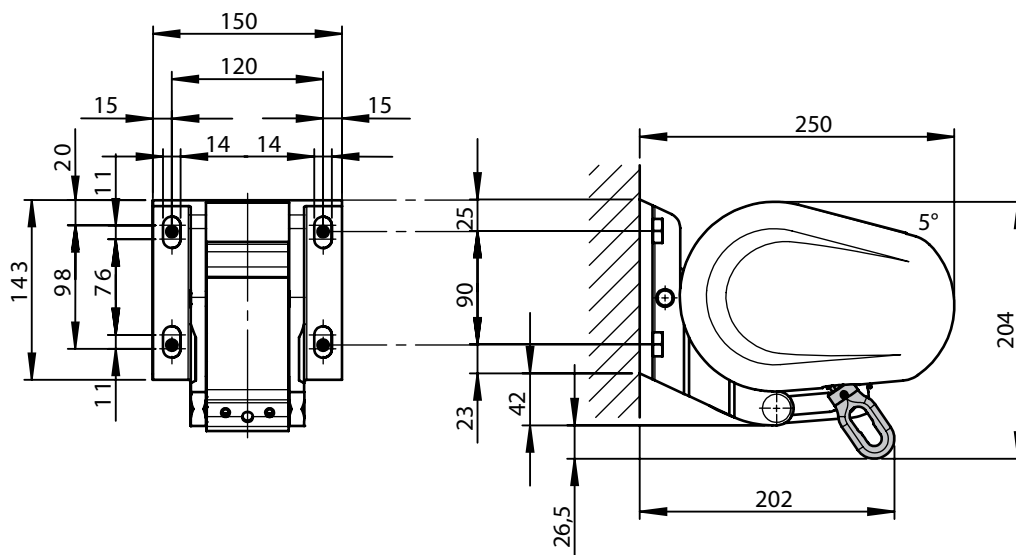

dimensions in mm

- 01
- 02
- 03
- 04
- 05
- 06
- 07
- 08
- 09
- 10
- 11
- 12
- 13
- 14
- 15
- 16
- 17
- 18
- 19
- 20
- 21
- 22
- 23

### Cable exit point in the case of motor-driven units

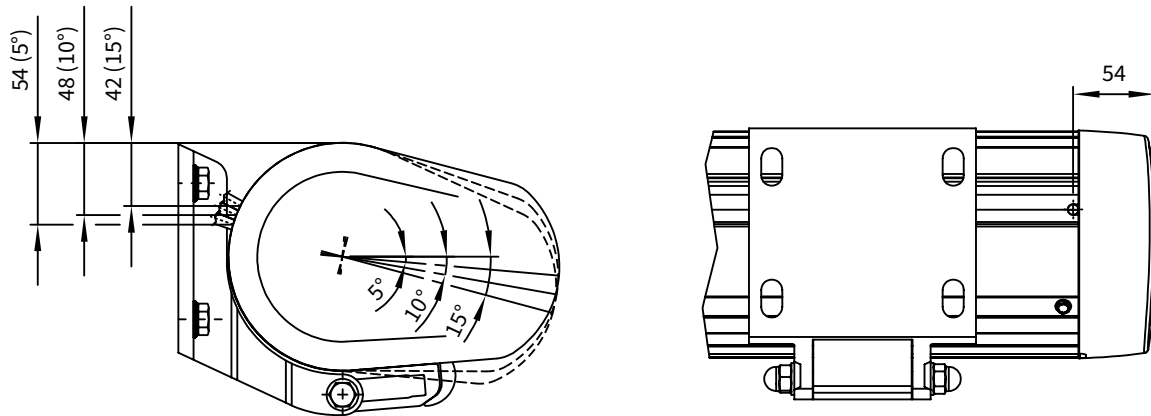

dimensions in mm



### Bracket fixture range for awnings with 2 folding arms

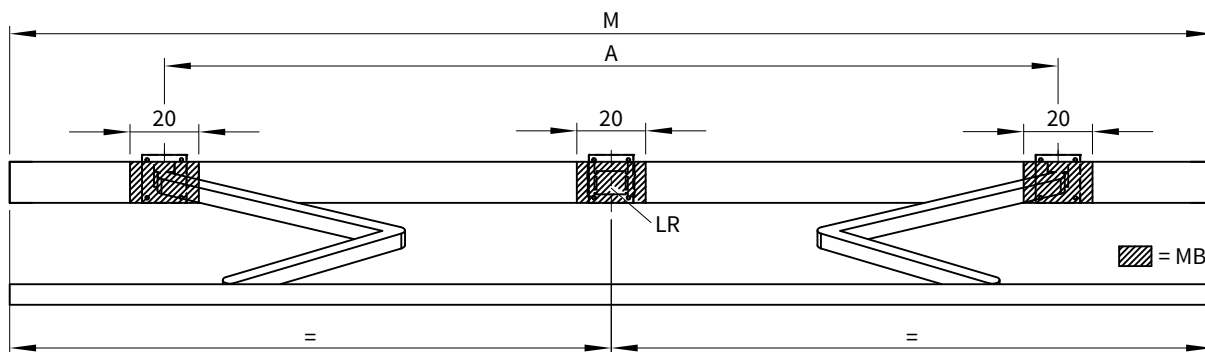

dimensions in cm

M [cm]	SB →	250	300	350	400	450	500	550	600	650
	ZB →	187–250	251–300	301–350	351–400	401–450	451–500	501–550	551–600	601–650

H [cm] ↓	A [cm]								
150	172**	220	270	300	340	380	440	490	510
200	222*	223**	270	300	340	380	440	490	510
250	-	272*	273**	300	340	390	440	490	510
300	-	-	322*	323**	340	390	440	490	510
350	-	-	-	372*	373**	390	440	490	-
400	-	-	-	-	422*	423*	440**	-	-

	BHT ↓	HT ↓	HT ↓
W	150 mm	2	3

DE / DA	135 mm	2	3

If the brackets cannot be positioned in accordance with this table, make sure the actual measurements are noted on the order form!

- \* = Please note the minimum widths! Dimension **A** is only valid for standard arms! Dimension **A** is 13 cm smaller in the case of bespoke arms. Coupled units are not available with junction roller.
- \*\* = Coupled units are only available with junction roller in the standard widths, in the case of other widths please ask us.
- A = arm position
- BHT = bracket width
- DA = eaves fixture
- DE = top fixture
- H = projection
- HT = no. of brackets
- LR = a rolltex bearing with accompanying bracket is always placed under a central seam
- M = awning width
- MB = bracket fixture range
- SB = standard width
- W = face fixture
- ZB = intermediate width

01  
02  
03  
04  
**05**  
06  
07  
08  
09  
10  
11  
12  
13  
14  
15  
16  
17  
18  
19  
20  
21  
22  
23

### Bracket fixture range for awnings with 3 folding arms

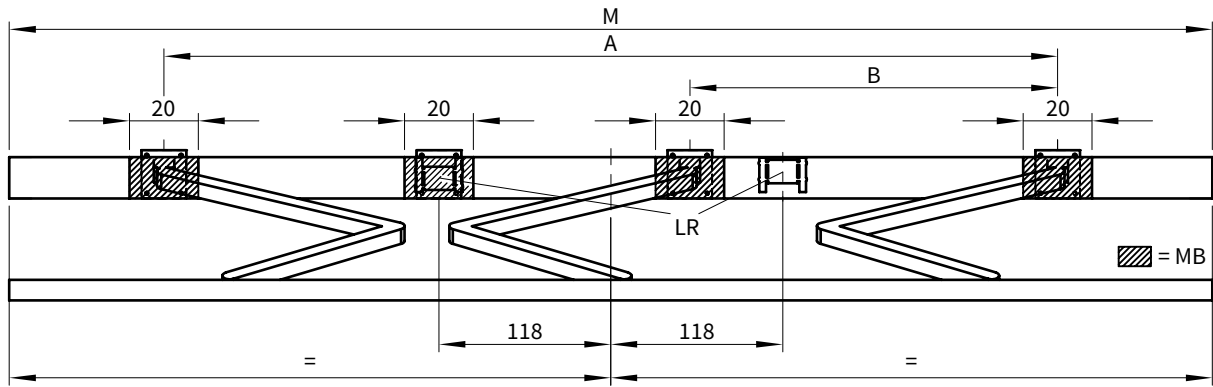

dimensions in cm

M[cm]	SB →	650		700			
	ZB →	601—650	650	651—674	675—700	446—695	696—700

H[cm]↓	A [cm]	B [cm]	A [cm]	B [cm]	A [cm]	B [cm]	A [cm]	B [cm]	A [cm]	B [cm]	A [cm]	B [cm]	KM[cm]
150	-	-	-	-	570	265	590	265	-	-	-	-	446
200	-	-	-	-	570	240	590	240	-	-	-	-	496
250	-	-	-	-	570	230	590	230	-	-	-	-	546
300	570 <sup>1)</sup>	230 <sup>1)</sup>	-	-	570	230	590	230	-	-	-	-	596
350	-	-	618 <sup>1)</sup>	220 <sup>1)</sup>	-	-	-	-	618 <sup>1)</sup>	225 <sup>1)</sup>	633	230	646
400	-	-	-	-	-	-	-	-	-	-	668 <sup>2)</sup>	235 <sup>2)</sup>	696

	BHT ↓	HT ↓
W	150 mm	4

DA/DE	135 mm	4
-------	--------	---

If the brackets cannot be positioned in accordance with this table, make sure the actual measurements are noted on the order form!

- 1) = Please note the minimum widths, only possible with a junction roller at a width of 700 cm.
- 2) = Please note the minimum widths, coupled units are not possible.
- 3) = arm position for awnings with spotlights
- A = arm position
- B = arm position
- BHT = bracket width
- DA = eaves fixture
- DE = top fixture
- H = projection
- HT = no. of brackets
- KM = minimum awning width
- LR = a rolltex bearing with accompanying bracket is always placed under a central seam
- M = awning width
- MB = bracket fixture range
- SB = standard width
- W = face fixture
- ZB = intermediate width

### markilux spotline for the markilux 5010

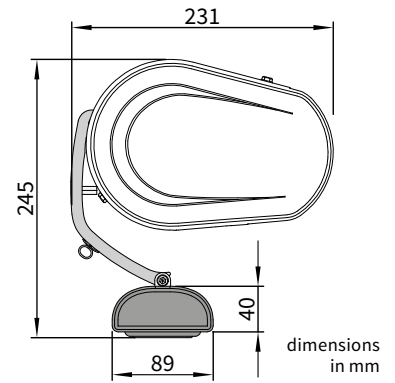
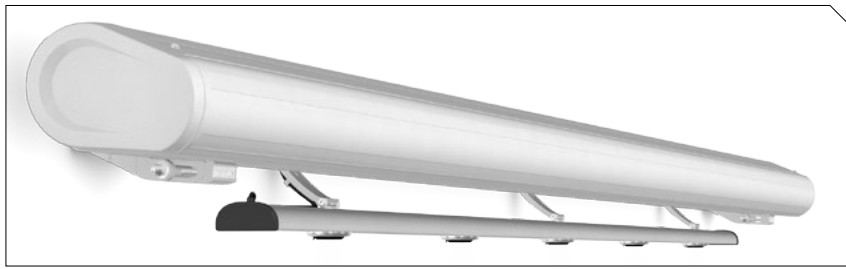

#### Light bar with fixture brackets for the cassette

With the markilux spotline the area underneath the awning is bathed evenly in a pleasant light.

The markilux spotline can be fitted or retrofitted to the cassette of the markilux 5010 using additional brackets.

The built-in spotlights can be adjusted individually – they can be rotated through 360° and tilted up to 60°.

Apart from the standard colours the cassette can – for a small surcharge – also be powder coated in other RAL colours to match the awning.

The markilux spotline is controlled via an on/off switch. It is wired to the mains by means of a connecting plug (Hirschmann).

Its construction makes it very quick to fit.

With the brackets already attached, the markilux spotline is suspended from the back joint in the cassette housing. It is then adjusted and tightened in place. The power supply cable is fixed in place using self-adhesive cable ties.

#### Quantity of brackets and their separation from one another

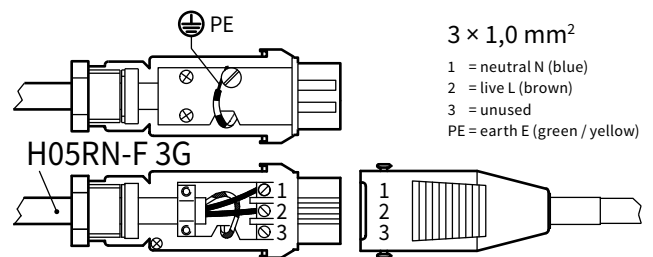
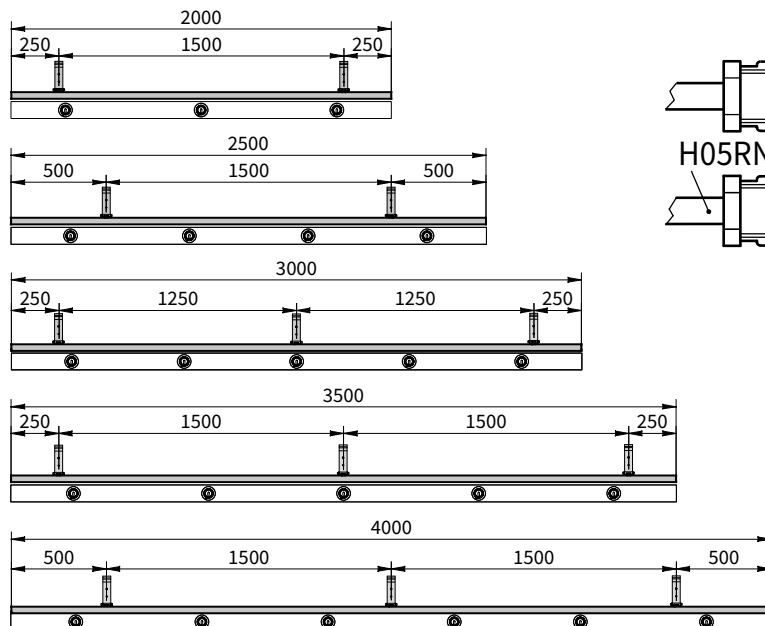

#### Housing colours

		standard	optional
traffic white	RAL 9016		
metallic aluminium	RAL 9006		
non-standard powder-coated finish			

#### Technical specification

power supply	230 V, 50 Hz				
ingress protection rating	IP44 / I				
wiring cross section	H05RN-F 3G 3 x 1.0 mm <sup>2</sup>				
power output (per spotlight)	20 W				
depth x height (cm)	89 mm x 40 mm				
length	200	250	300	350	400
no. of spotlights	3	4	5	5	6

Colours similar to those in the RAL chart. Colours may differ slightly from those depicted in both hue and finish.

