



markilux 1600

**Excellent design and well-thought-out mechanics –
the semi-cassette awning with a projection of up to 400 cm**





side view with awning retracted, face fixture



side view with awning retracted, top fixture

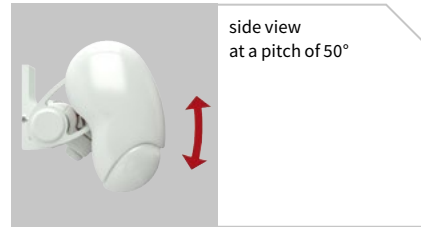

side view at a pitch of 50°

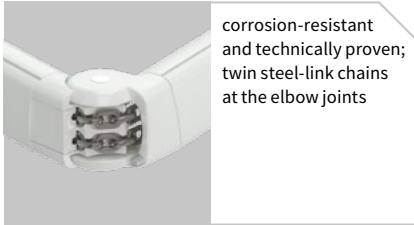

corrosion-resistant and technically proven; twin steel-link chains at the elbow joints



pitch adjustment via the fixture brackets

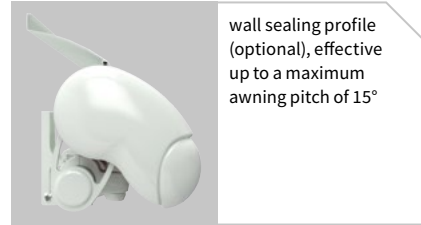

wall sealing profile (optional), effective up to a maximum awning pitch of 15°



folding arms with bionic tendon (optional)

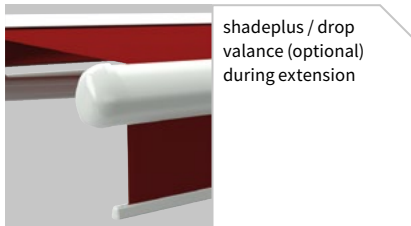

shadeplus / drop valance (optional) during extension

Design Features

presented with the IF Design Award for excellent design

folding-arm awning in a semi-cassette version. The dynamically rounded coverboard gives the awning the appearance of being fully cassetted.

elegant and robust front profile made of aluminium

Technical Specification

the extremely sturdy awning construction makes it possible to shade even very large areas safely

sturdy, round steel torque bar, 50 mm Ø, to prevent twist and deflection

coverboard with integrated brush, so that larger pieces of dirt and debris cannot be drawn into the awning

the 85 mm roller tube ensures the highest stiffness and the best possible cover winding characteristics even at the largest widths

folding arms with perfected power transference by means of twin, steel-link chains and direct coupling of the springs. High security even in the case of large arm lengths.

Optional Accessories

the shadeplus creates an additional room on the patio; protection from the sun, the wind and inquisitive glances all in one

radio-controlled motor with radio remote control for ease of use

hard-wired motor operation (optionally with automatic weather controls) for straightforward and easy operation

in the case of manual operation ease of use is ensured with the spring-assisted gearbox

wall sealing profile to cover the gap between awning and wall

available with a valance

awning available in non-standard RAL colours

Lounge colours

markilux 1600

off-white textured finish 5233

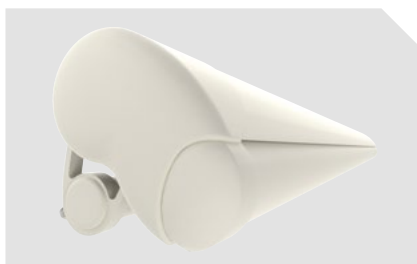

Designer end caps in polished chrome

off-white textured finish 5233



stone grey metallic 5215



stone grey metallic 5215



Havana brown textured finish 5229



Havana brown textured finish 5229

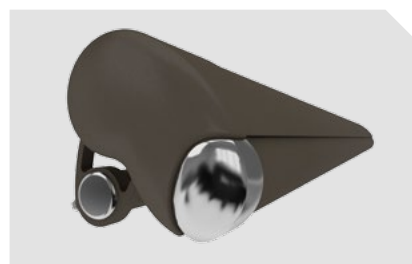

anthracite metallic 5204





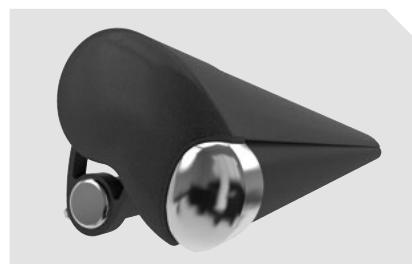





anthracite metallic 5204

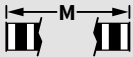
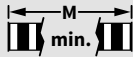

- 01
- 02
- 03
- 04
- 05
- 06
- 07
- 08
- 09
- 10
- 11
- 12
- 13
- 14
- 15
- 16
- 17
- 18
- 19
- 20
- 21
- 22
- 23

Colours may differ slightly from those depicted in both hue and finish.

Dimensions and configuration options

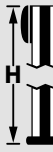
																
		260	310	360	410	460	510	560	610	660	710 ³⁾					
		174 260	261 310	311 360	361 410	411 460	461 510	511 560	561 610	611 660	661 710					
	150	3)										187	174	661	190	177
	200	3)										237	224	661	240	227
	250	-	3)									287	274	661	290	277
	300	-	-	3)								337	324	661	340	327
	350	-	-	-	3)						1)	387	374	661	390	377
	400 ^{1) 2)}	-	-	-	-	3)					-	437	424	687	-	-

dimensions in cm

= 
 =  
 =  

- 1) a shadeplus / drop valance is not possible
- 2) awnings with 3 arms or a projection of 400 cm are only available with motor
- 3) please note the minimum widths!

Operation / Drive

	standard	optional
manual operation	<input checked="" type="checkbox"/>	-
servo-assisted operation	-	<input checked="" type="checkbox"/>
hard-wired motor	-	<input checked="" type="checkbox"/>
io radio controls	-	<input checked="" type="checkbox"/>
radio-controlled motor (433 MHz)	-	<input checked="" type="checkbox"/>

Shadeplus / drop valance

	standard	optional
manual operation	-	<input checked="" type="checkbox"/>
hard-wired motor	-	<input checked="" type="checkbox"/>
radio-controlled motor (433 MHz)	-	<input checked="" type="checkbox"/>



Covers



	fabric range no.	standard	optional
sunsilk snc	324 .. / 328 .. / 369 ..	<input checked="" type="checkbox"/>	-
sunsilk perla FR	374 ..	-	<input checked="" type="checkbox"/>
sunvas snc	310 .. / 311 .. 313 .. - 315 ..	<input checked="" type="checkbox"/>	-
sunvas perla	370 ..	-	<input checked="" type="checkbox"/>

Coupled units

	standard	optional
2 fields	-	<input checked="" type="checkbox"/> ⁴⁾
junction roller	-	<input checked="" type="checkbox"/> ⁵⁾









- 4) for minimum widths please consult the section "Technical Information"
- 5) see overview "Bracket fixture range"

 = motor
  = manual operation
M = awning width

 = no. of folding arms
  = no. of bespoke arms
M min. = minimum widths

 = no. of rolltex bearings
 H = projection

Frame colours

		standard	optional
traffic white	RAL 9016		
metallic aluminium	RAL 9006		
grey brown, similar to	RAL 8019		
light ivory	RAL 1015		
anthracite metallic	5204		
stone grey metallic	5215		
off-white textured finish	5233		
Havana brown textured finish	5229		
non-standard powder-coated finish			

Other end cap colour options

	standard	optional
polished chrome		

Miscellaneous

	standard	optional
bionic tendon	—	<input checked="" type="checkbox"/>
wall sealing profile	—	<input checked="" type="checkbox"/> ¹⁾
light and wind sensor	—	<input checked="" type="checkbox"/>
insertable side blind	—	<input checked="" type="checkbox"/>
valance	—	<input checked="" type="checkbox"/>
infrared heater	—	<input checked="" type="checkbox"/>
vibrabox / radio control light sensor Sunis WireFree	—	<input checked="" type="checkbox"/>

1) up to a maximum awning pitch of 15°

Additional information

The width of the awning cover is always **less** than that of the awning. Please refer cover sizes in the case of coupled units and those with more than 2 arms to us.

Pitch adjustment range: from 5° to 50° (to the horizontal).

Definition of projection:

Please consult the section “Technical Information”.

In the case of manual operation approximately **16 winding handle revolutions can be assumed per metre of awning projection.**

It takes approximately **12 seconds per metre** to extend the awning in the case of **motor-driven units.**

Definition of shadeplus drop: The shadeplus drop is measured from the bottom edge of the shadeplus profile to the bottom edge of the valance profile. Due to fabric thickness tolerances the actual drop may be shorter than the nominal drop by up to 5 cm. For the maximum shadeplus drops please consult the section “Technical Information”.

A shadeplus is not available with sunsilk perla FR, sunvas perla or PVC covers.

Coupled folding-arm awnings are available up to a **max. of 2 single units** side by side, however **only with a motor.**

A coupled unit is available with **junction roller.** Pattern repeat mismatches are possible in the case of junction roller covers. A junction roller may not fit when the projection is the maximum for the width of each awning. (see also the section on “Installation”, the arm separation table).

If coupled awnings are fitted into a **recess or reveal** the overall width of the coupled awning must be at least 6 cm less than the width of the opening to allow the awning to be coupled.

Dimensions and tolerances

	width	projection
housing tolerances	+5 / -15 mm	±40 mm
awning cover width = awning width	-260 mm	
awning cover length = awning projection		+180 mm

Colours similar to those in the RAL chart. Colours may differ slightly from those depicted in both hue and finish.

01
02
03
04
05
06
07
08
09
10
11
12
13
14
15
16
17
18
19
20
21
22
23

Fixtures, fittings and accessories

Fixture brackets

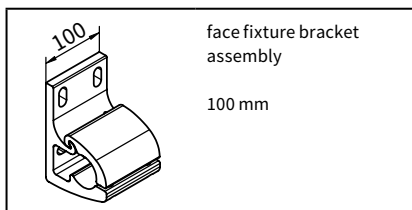

face fixture bracket assembly

100 mm

70867.

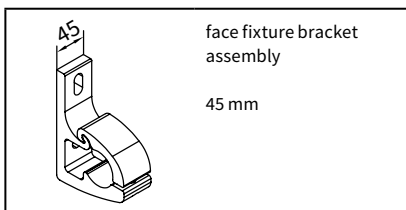

face fixture bracket assembly

45 mm

71813.

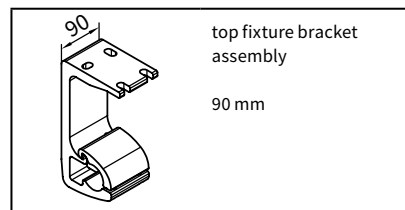

top fixture bracket assembly

90 mm

70868.

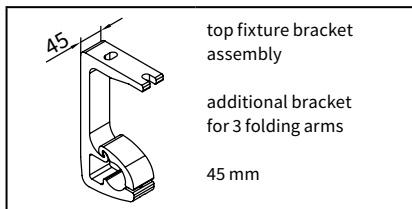

top fixture bracket assembly

additional bracket for 3 folding arms

45 mm

71818.

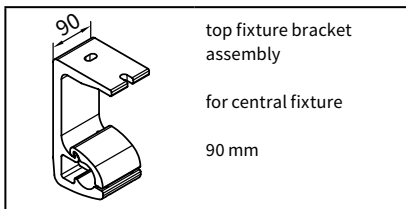

top fixture bracket assembly for central fixture

90 mm

70869.

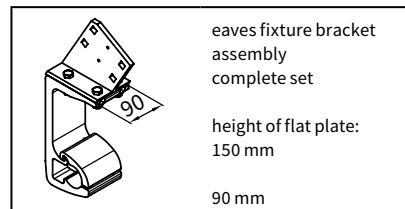

eaves fixture bracket assembly complete set

height of flat plate: 150 mm

90 mm

70871.

Spreader and spacer plates

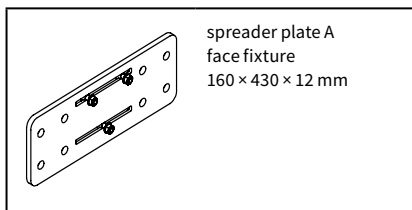

spreader plate A face fixture

160 × 430 × 12 mm

75326.

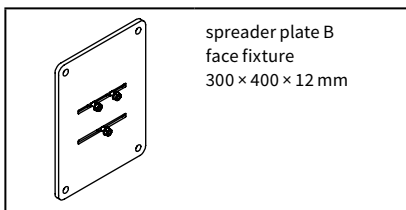

spreader plate B face fixture

300 × 400 × 12 mm

75325.

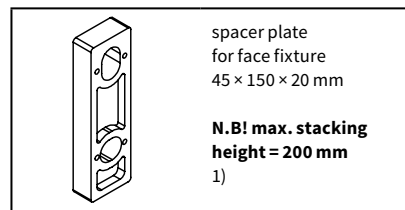

spacer plate for face fixture

45 × 150 × 20 mm

N.B! max. stacking height = 200 mm
1)

718251

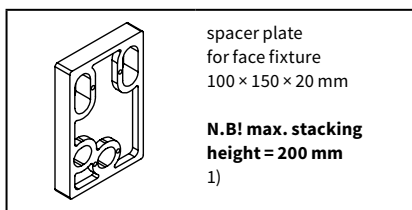

spacer plate for face fixture

100 × 150 × 20 mm

N.B! max. stacking height = 200 mm
1)

718231

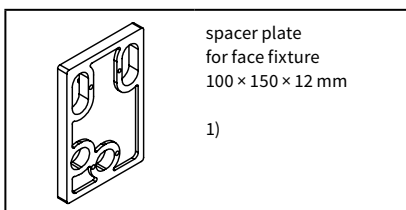

spacer plate for face fixture

100 × 150 × 12 mm

1)

718241

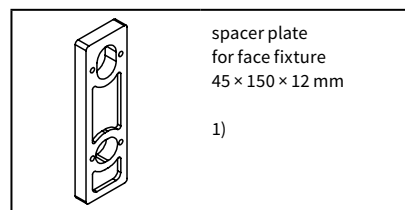

spacer plate for face fixture

45 × 150 × 12 mm

1)

71826.

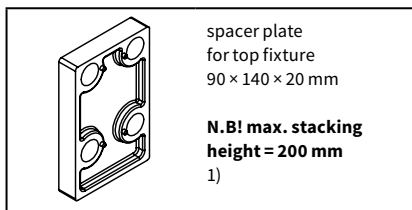

spacer plate for top fixture

90 × 140 × 20 mm

N.B! max. stacking height = 200 mm
1)

716311

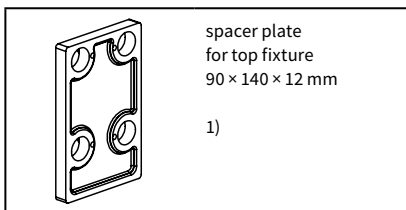

spacer plate for top fixture

90 × 140 × 12 mm

1)

716411

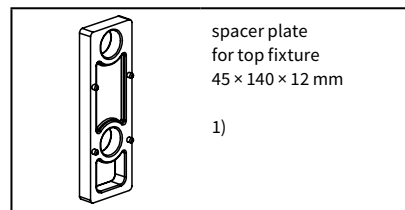

spacer plate for top fixture

45 × 140 × 12 mm

1)

716371

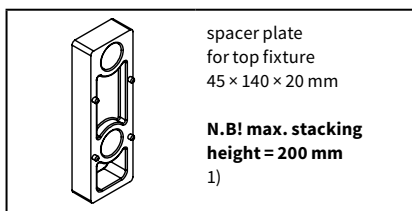

spacer plate for top fixture

45 × 140 × 20 mm

N.B! max. stacking height = 200 mm
1)

716261

1) please refer to the section "Technical Information"

. = insert RAL colour code no

01
02
03
04
05
06
07
08
09
10
11
12
13
14
15
16
17
18
19
20
21
22
23

Stand-off brackets

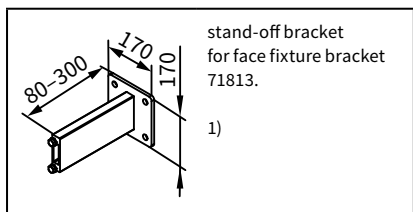

stand-off bracket for face fixture bracket 71813.

1)

77967.

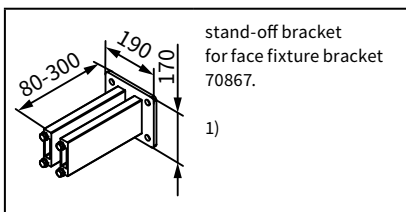

stand-off bracket for face fixture bracket 70867.

1)

77968.

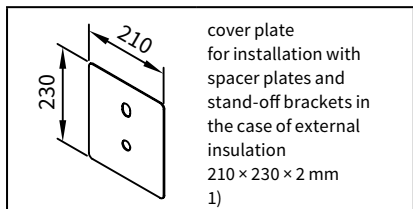

cover plate for installation with spacer plates and stand-off brackets in the case of external insulation

210 x 230 x 2 mm

1)

71844.

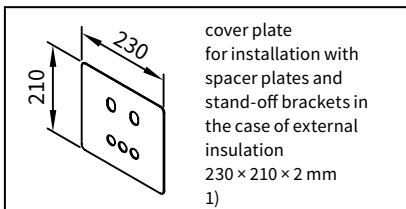

cover plate for installation with spacer plates and stand-off brackets in the case of external insulation

230 x 210 x 2 mm

1)

71843.

Accessories

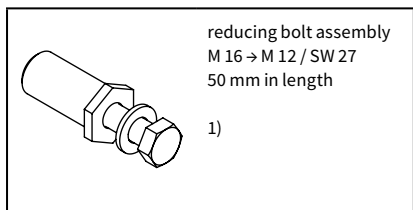

reducing bolt assembly M 16 → M 12 / SW 27 50 mm in length

1)

753891

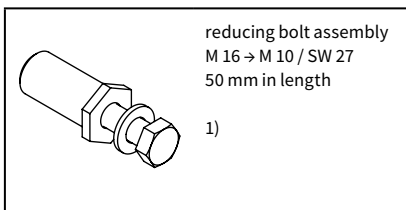

reducing bolt assembly M 16 → M 10 / SW 27 50 mm in length

1)

754921

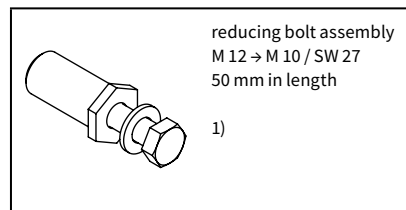

reducing bolt assembly M 12 → M 10 / SW 27 50 mm in length

1)

754911

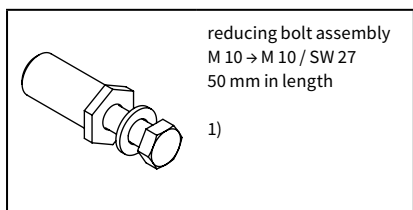

reducing bolt assembly M 10 → M 10 / SW 27 50 mm in length

1)

754901

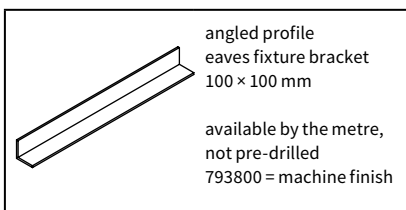

angled profile eaves fixture bracket 100 x 100 mm

available by the metre, not pre-drilled 793800 = machine finish

79380.

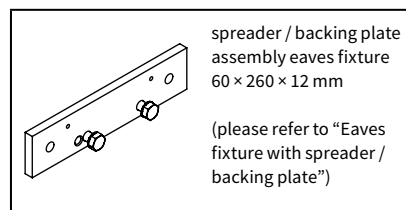

spreader / backing plate assembly eaves fixture 60 x 260 x 12 mm

(please refer to "Eaves fixture with spreader / backing plate")

75383.

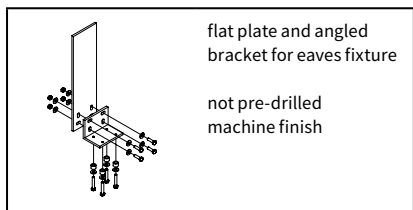

flat plate and angled bracket for eaves fixture

not pre-drilled machine finish

716620

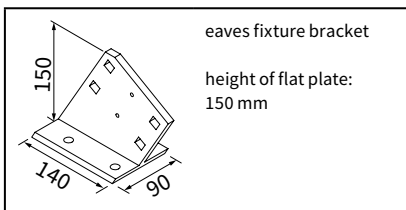

eaves fixture bracket

height of flat plate: 150 mm

71612.

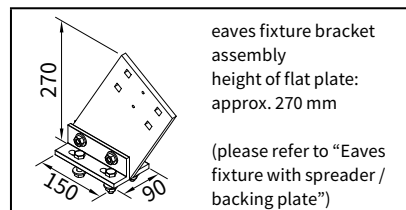

eaves fixture bracket assembly

height of flat plate: approx. 270 mm

(please refer to "Eaves fixture with spreader / backing plate")

71659.

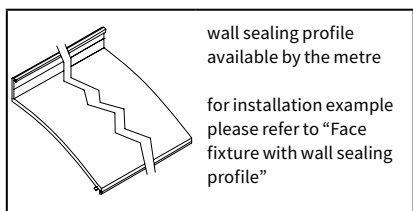

wall sealing profile available by the metre

for installation example please refer to "Face fixture with wall sealing profile"

77780.

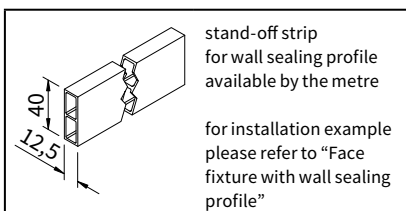

stand-off strip for wall sealing profile available by the metre

for installation example please refer to "Face fixture with wall sealing profile"

751971

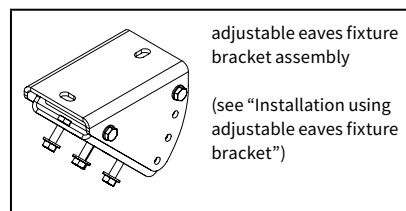

adjustable eaves fixture bracket assembly

(see "Installation using adjustable eaves fixture bracket")

71198.

1) please refer to the section "Technical Information"

. = insert RAL colour code no

Face fixture

Pull-out force [N=Newton] per upper fixing point according to EN 13561, wind resistance class 2

Compression-proof substrate
M [cm]

260	310	360	410	460	510	560	610	660	710
-----	-----	-----	-----	-----	-----	-----	-----	-----	-----

Non compression-proof substrate
M [cm]

260	310	360	410	460	510	560	610	660	710
-----	-----	-----	-----	-----	-----	-----	-----	-----	-----

H [cm]	FB [N]									
150	452	515	579	642	706	769	833	896	960	729
200	698	799	899	1000	1100	1201	1301	1402	1502	1138
250	-	1180	1326	1471	1617	1762	1907	2053	2479	1874
300	-	-	1783	1981	2179	2377	2917	3147	3377	2548
350	-	-	-	2563	3200	3502	3804	4106	4408	3321
400	-	-	-	-	4039	4423	4806	5190	-	4194

H [cm]	FB [N]									
150	617	704	791	878	965	1051	1138	1225	1312	996
200	954	1091	1229	1366	1503	1641	1778	1916	2053	1555
250	-	1613	1812	2011	2209	2408	2607	2805	3388	2562
300	-	-	2437	2708	2978	3249	3989	4300	4615	3482
350	-	-	-	3503	4373	4786	5199	5612	6025	4539
400	-	-	-	-	5519	6044	6569	7094	-	5732

HT BHT	2 100 mm	2 100 mm 1 45 mm	3 100 mm 1 45 mm
----------	------------	-------------------------	-------------------------

HT BHT	2 100 mm	2 100 mm 1 45 mm	3 100 mm 1 45 mm
----------	------------	-------------------------	-------------------------

BM	6	8	11
----	---	---	----

BM	6	8	11
----	---	---	----

The pull-out force refers to the vertical centre to centre measurement between the fixture points of **90 mm**. If this measurement is reduced to the minimum, the pull-out force increases by **14%** in the case of **compression-proof substrates** and by **19%** in the case of **non compression-proof substrates**.

If the awning is fixed with 2 brackets per folding arm, the pull-out force can be halved.

Place the brackets immediately to the left and right of the arm bearer.

- M = awning width
- H = projection
- FB = pull-out force per fixing point
- HT | BHT = bracket quantity | width
- BM = no. of fixing points
- WA = wall sealing profile
- 71813. = face fixture bracket assembly 45 mm
- 70867. = face fixture bracket assembly 100 mm

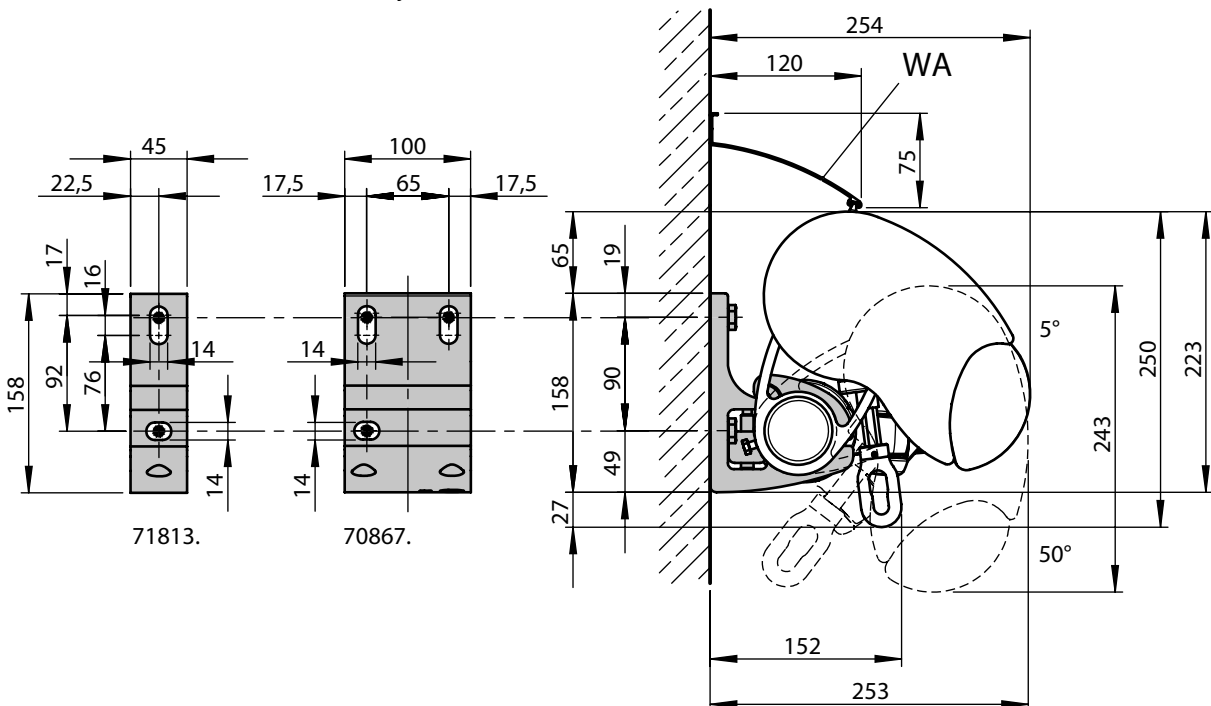

dimensions in mm

Face fixture with spreader plate A

Pull-out force [N=Newton] per upper fixing point according to EN 13561, wind resistance class 2

Compression-proof substrate											Non compression-proof substrate										
M [cm]											M [cm]										
H [cm]											H [cm]										
FB [N]											FB [N]										
	260	310	360	410	460	510	560	610	660	710		260	310	360	410	460	510	560	610	660	710
150	260	297	334	370	407	443	480	517	553	420	370	422	474	526	578	630	682	734	786	597	
200	401	459	517	575	632	690	748	806	864	654	570	652	735	817	899	981	1063	1145	1227	930	
250	-	678	761	844	928	1011	1095	1178	1423	1076	-	963	1081	1200	1319	1437	1556	1674	2022	1529	
300	-	-	1022	1136	1249	1363	1672	1804	1936	1461	-	-	1453	1614	1775	1937	2376	2564	2751	2076	
350	-	-	-	1468	1833	2006	2179	2352	2525	1903	-	-	-	2087	2605	2851	3097	3343	3589	2704	
400	-	-	-	-	2312	2532	2752	2971	-	2401	-	-	-	-	3286	3598	3910	4222	-	3412	
HT BHT	2 100 mm			2 100 mm 1 45 mm			3 100 mm 1 45 mm				2 100 mm			2 100 mm 1 45 mm			3 100 mm 1 45 mm				
BP	2			2			3				2			2			3				
DP	-			1			1				-			1			1				
BM	16			18			26				16			18			26				

The pull-out force refers to the vertical centre to centre measurement between the fixture points of 76 mm. In the case of spreader plates a washer conforming to DIN 9021 must be used.

- M = awning width
- H = projection
- FB = pull-out force per fixing point
- HT | BHT = bracket quantity | width
- BP = no. of spreader plates
- DP = no. of spacer plates
- BM = no. of fixing points
- WA = wall sealing profile
- 75197. = stand-off strip for wall sealing profile

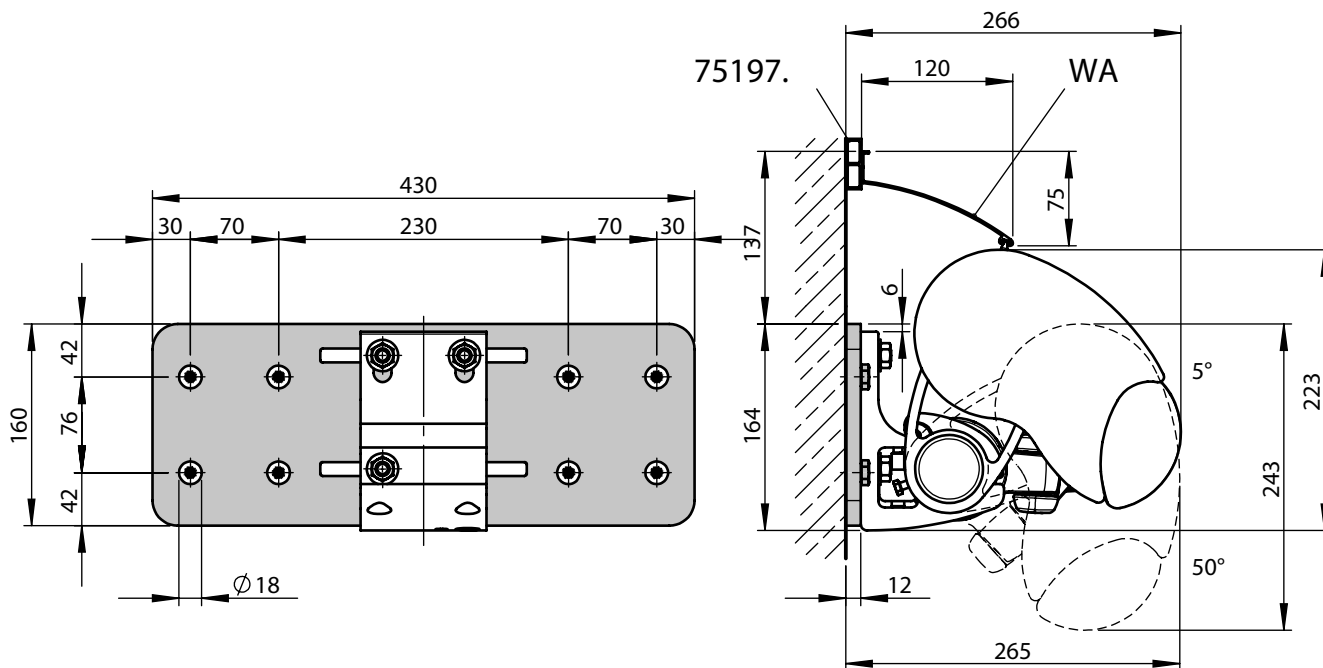

dimensions in mm

01
02
03
04
05
06
07
08
09
10
11
12
13
14
15
16
17
18
19
20
21
22
23

Face fixture with spreader plate B

Pull-out force [N=Newton] per upper fixing point according to EN 13561, wind resistance class 2

Compression-proof substrate
M [cm]

260	310	360	410	460	510	560	610	660	710
-----	-----	-----	-----	-----	-----	-----	-----	-----	-----

Non compression-proof substrate
M [cm]

260	310	360	410	460	510	560	610	660	710
-----	-----	-----	-----	-----	-----	-----	-----	-----	-----

H [cm]	FB [N]									
150	154	176	197	219	241	262	284	306	327	249
200	238	272	306	340	374	408	443	477	511	387
250	-	401	450	500	549	598	648	697	842	637
300	-	-	605	672	739	807	990	1068	1146	865
350	-	-	-	869	1085	1187	1290	1392	1494	1126
400	-	-	-	-	1368	1498	1628	1758	-	1421

H [cm]	FB [N]									
150	161	183	206	228	251	274	296	319	341	259
200	248	283	319	355	390	426	462	497	533	404
250	-	418	470	521	573	624	676	727	878	664
300	-	-	631	701	771	841	1032	1113	1195	902
350	-	-	-	906	1131	1238	1345	1452	1559	1174
400	-	-	-	-	1427	1562	1698	1834	-	1482

HT BHT	2 100 mm	2 100 mm 1 45 mm	3 100 mm 1 45 mm
----------	------------	-------------------------	-------------------------

HT BHT	2 100 mm	2 100 mm 1 45 mm	3 100 mm 1 45 mm
----------	------------	-------------------------	-------------------------

BP	2	2	3
DP	-	1	1
BM	8	10	14

BP	2	2	3
DP	-	1	1
BM	8	10	14

The pull-out force refers to the vertical centre to centre measurement between the fixture points of **350 mm**.
In the case of spreader plates a washer conforming to DIN 9021 must be used.

- M = awning width
- H = projection
- FB = pull-out force per fixing point
- HT | BHT = bracket quantity | width
- BP = no. of spreader plates
- DP = no. of spacer plates
- BM = no. of fixing points

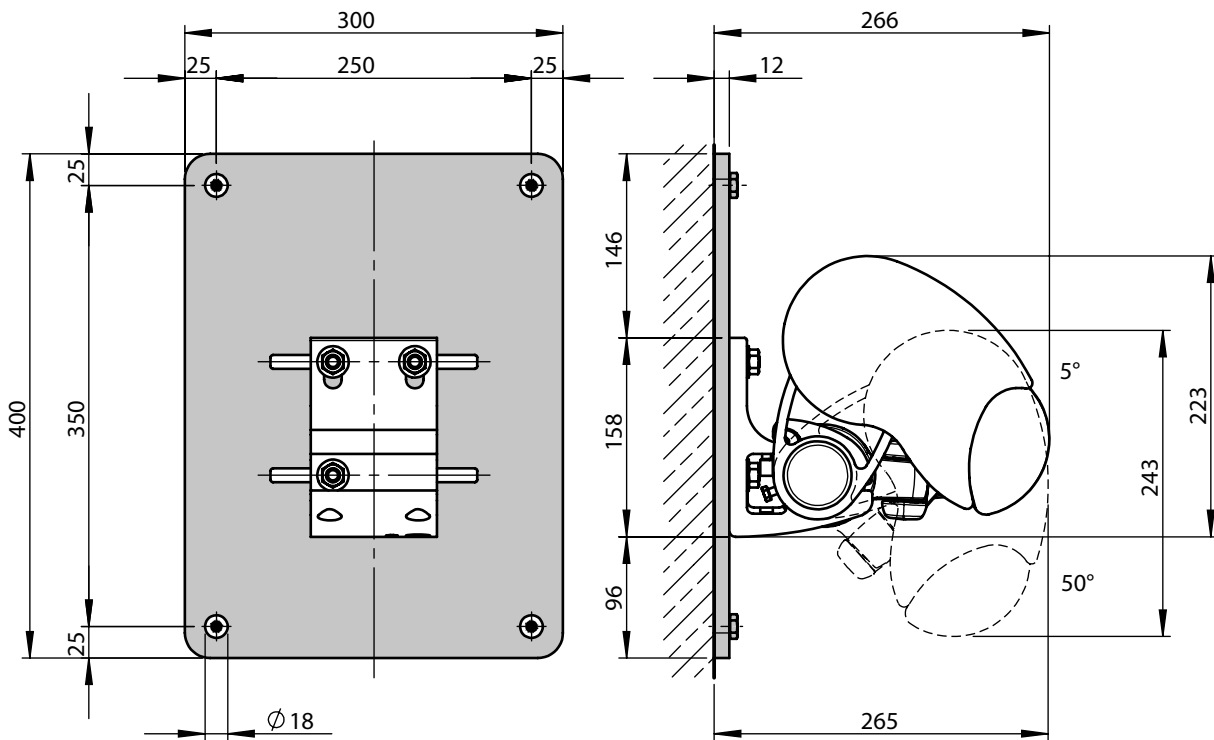

dimensions in mm

Face fixture with stand-off brackets

Pull-out force [N=Newton] per upper fixing point according to EN 13561, wind resistance class 2

Compression-proof substrate										Non compression-proof substrate										
M [cm]										M [cm]										
H [cm]										H [cm]										
FB [N]										FB [N]										
260	310	360	410	460	510	560	610	660	710	260	310	360	410	460	510	560	610	660	710	
150	541	615	690	765	840	915	990	1065	1139	867	608	692	777	861	945	1029	1113	1198	1282	976
200	792	904	1017	1130	1243	1356	1469	1582	1694	1286	891	1018	1144	1271	1398	1525	1652	1779	1906	1447
250	-	1292	1450	1608	1766	1924	2082	2240	2713	2054	-	1454	1631	1809	1987	2165	2342	2520	3052	2310
300	-	-	1902	2112	2323	2533	3114	3359	3604	2722	-	-	2140	2376	2613	2850	3503	3779	4054	3062
350	-	-	-	2682	3353	3669	3985	4301	4617	3481	-	-	-	3018	3772	4128	4483	4839	5194	3916
400	-	-	-	-	4170	4566	4961	5357	-	4331	-	-	-	-	4691	5136	5582	6027	-	4872
HT BHT	2 100 mm			2 100 mm 1 45 mm			3 100 mm 1 45 mm			2 100 mm			2 100 mm 1 45 mm			3 100 mm 1 45 mm				
BP	2			2			3			2			2			3				
DP	-			1			1			-			1			1				
BM	8			12			16			8			12			16				

The pull-out force refers to the vertical centre to centre measurement between the fixture points of **120 mm**.

In the case of stand-off brackets washers conforming to DIN 9021 must be used.

- M = awning width
- H = projection
- FB = pull-out force per fixing point
- HT | BHT = bracket quantity | width
- BM = no. of fixing points
- DH = no. of stand-off brackets
- 77967. = stand-off bracket for face fixture bracket assembly 70813.
- 77968. = stand-off bracket for face fixture bracket assembly 70867.

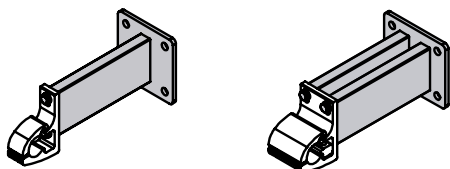

77967.

77968.

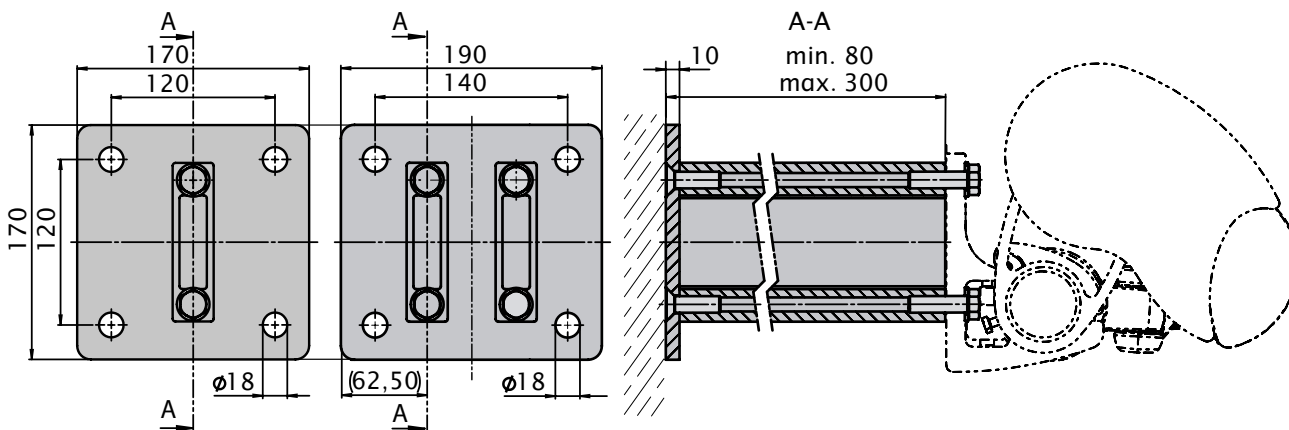

dimensions in mm

01
02
03
04
05
06
07
08
09
10
11
12
13
14
15
16
17
18
19
20
21
22
23

Face fixture with shadeplus

Pull-out force [N=Newton] per upper fixing point according to EN 13561, wind resistance class 2

Compression-proof substrate
M [cm]

260	310	360	410	460	510	560	610	660	710
-----	-----	-----	-----	-----	-----	-----	-----	-----	-----

Non compression-proof substrate
M [cm]

260	310	360	410	460	510	560	610	660	710
-----	-----	-----	-----	-----	-----	-----	-----	-----	-----

H [cm] FB [N]

150	529	608	686	765	843	922	1000	1079	1157	870
200	802	922	1043	1163	1284	1404	1524	1645	1765	1327
250	-	1335	1505	1676	1846	2016	2186	2357	2808	2110
300	-	-	1998	2226	2454	2682	3252	3512	3771	2831
350	-	-	-	2850	3521	3858	4195	4532	-	3652

H [cm] FB [N]

150	724	831	938	1045	1153	1260	1367	1474	1582	1190
200	1096	1260	1425	1590	1754	1919	2083	2248	2413	1813
250	-	1824	2057	2290	2523	2755	2988	3221	3838	2884
300	-	-	2731	3043	3354	3666	4444	4799	5154	3869
350	-	-	-	3894	4812	5272	5733	6194	-	4990

HT BHT	2 100 mm	2 100 mm 1 45 mm	3 100 mm 1 45 mm
----------	------------	-------------------------	-------------------------

HT BHT	2 100 mm	2 100 mm 1 45 mm	3 100 mm 1 45 mm
----------	------------	-------------------------	-------------------------

BM	6	8	11
----	---	---	----

BM	6	8	11
----	---	---	----

The pull-out force refers to the vertical centre to centre measurement between the fixture points of **90 mm**. If this measurement is reduced to the minimum, the pull-out force increases by **14%** in the case of **compression-proof substrates** and by **19%** in the case of **non compression-proof substrates**.

If the awning is fixed with 2 brackets per folding arm, the pull-out force can be halved.

Place the brackets immediately to the left and right of the arm bearer.

- M = awning width
- H = projection
- FB = pull-out force per fixing point
- HT | BHT = bracket quantity | width
- BM = no. of fixing points
- WA = wall sealing profile
- 71813. = face fixture bracket assembly 45 mm
- 70867. = face fixture bracket assembly 100 mm

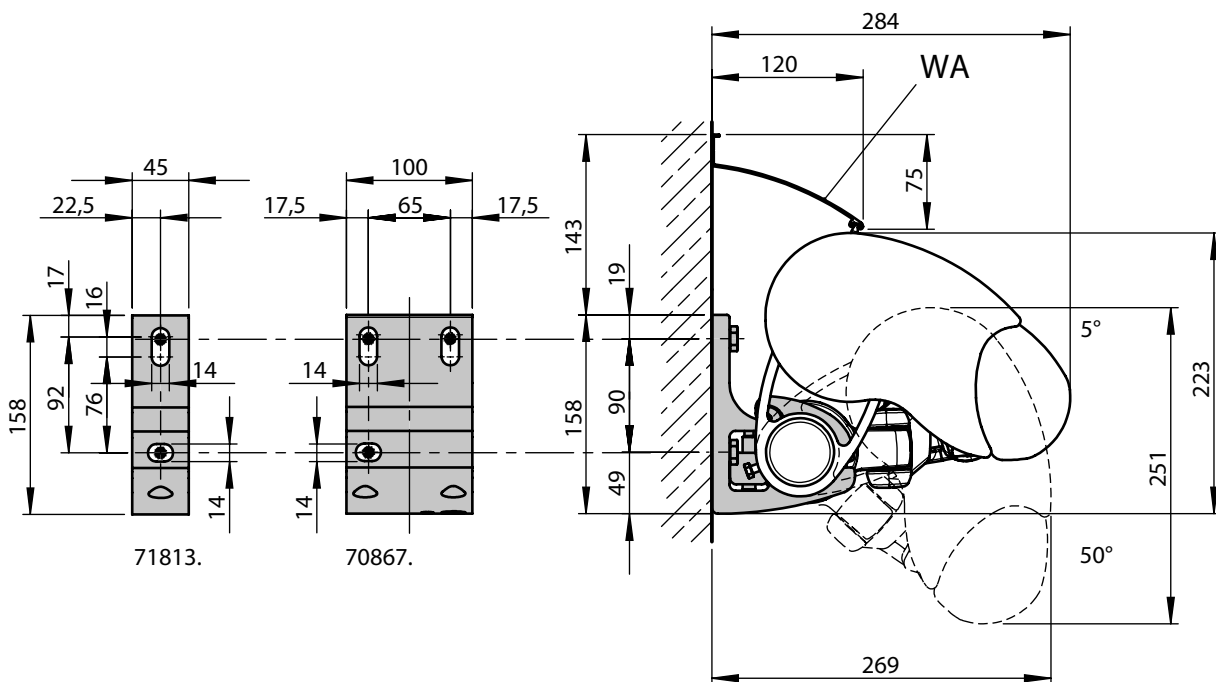

dimensions in mm

Face fixture with shadeplus and spreader plate A

Pull-out force [N=Newton] per upper fixing point according to EN 13561, wind resistance class 2

Compression-proof substrate											Non compression-proof substrate										
M [cm]											M [cm]										
H [cm]											H [cm]										
FB [N]											FB [N]										
	260	310	360	410	460	510	560	610	660	710		260	310	360	410	460	510	560	610	660	710
150	305	350	395	441	486	531	576	621	667	501	434	498	562	626	690	755	819	883	947	712	
200	461	530	599	668	738	807	876	945	1014	722	655	753	851	950	1048	1146	1245	1343	1441	1026	
250	-	766	864	961	1059	1157	1254	1352	1611	1211	-	1089	1227	1366	1505	1644	1783	1921	2290	1721	
300	-	-	1145	1276	1407	1537	1864	2013	2162	1623	-	-	1628	1813	1999	2185	2649	2860	3072	2306	
350	-	-	-	1632	2016	2209	2403	2596	-	2091	-	-	-	2319	2866	3140	3414	3688	-	2972	
HT BHT	2 100 mm					2 100 mm		3 100 mm		2 100 mm					2 100 mm		3 100 mm				
						1 45 mm		1 45 mm							1 45 mm		1 45 mm				
BP	2					2		3		2					2		3				
DP	-					1		1		-					1		1				
BM	16					18		26		16					18		26				

The pull-out force refers to the vertical centre to centre measurement between the fixture points of **76 mm**.
In the case of spreader plates a washer conforming to DIN 9021 must be used.

- M = awning width
- H = projection
- FB = pull-out force per fixing point
- HT | BHT = bracket quantity | width
- BP = no. of spreader plates
- DP = no. of spacer plates
- BM = no. of fixing points
- WA = wall sealing profile
- 75197. = stand-off strip for wall sealing profile

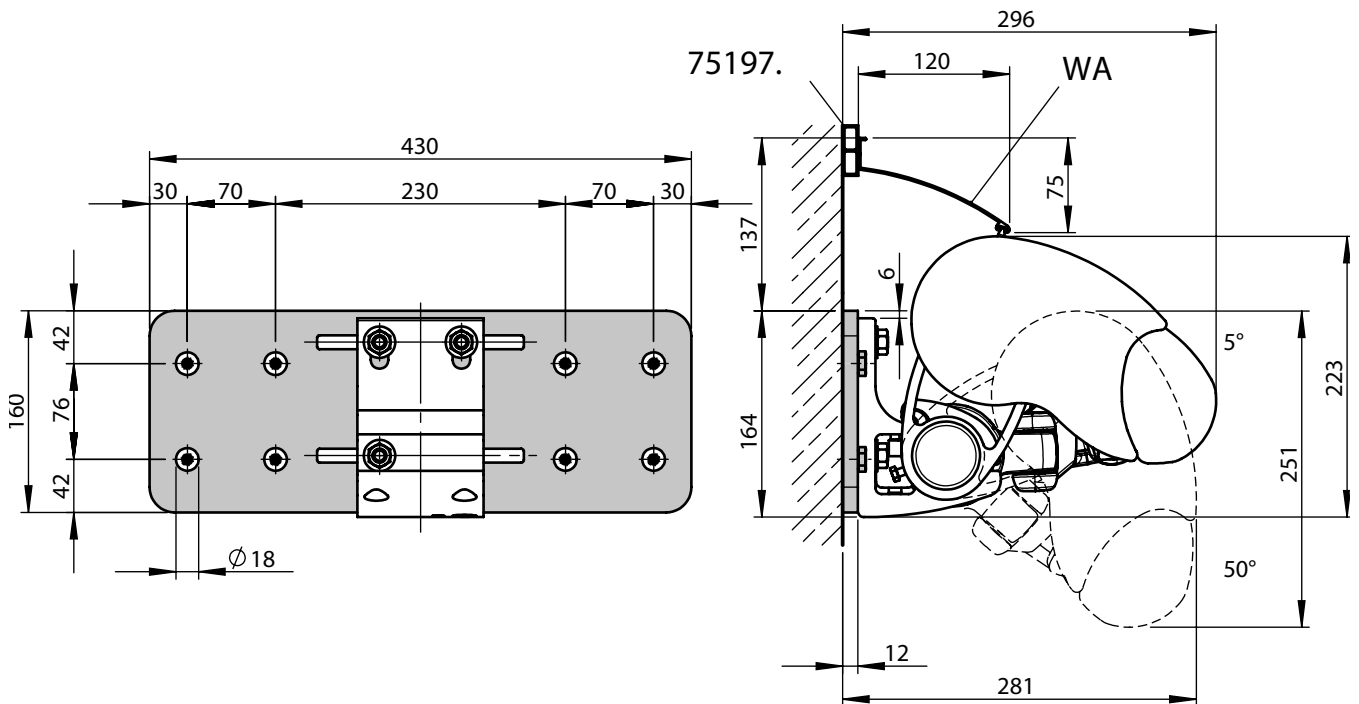

dimensions in mm

01
02
03
04
05
06
07
08
09
10
11
12
13
14
15
16
17
18
19
20
21
22
23

Face fixture with shadeplus and spreader plate B

Pull-out force [N=Newton] per upper fixing point according to EN 13561, wind resistance class 2

Compression-proof substrate
M [cm]

260	310	360	410	460	510	560	610	660	710
-----	-----	-----	-----	-----	-----	-----	-----	-----	-----

Non compression-proof substrate
M [cm]

260	310	360	410	460	510	560	610	660	710
-----	-----	-----	-----	-----	-----	-----	-----	-----	-----

H [cm]	FB [N]									
150	181	207	234	261	287	314	341	368	394	297
200	273	314	355	396	436	477	518	559	600	451
250	-	453	511	569	627	685	742	800	954	717
300	-	-	678	755	832	910	1103	1191	1279	960
350	-	-	-	966	1193	1308	1422	1536	-	1238

H [cm]	FB [N]									
150	188	216	244	272	300	328	356	383	411	309
200	284	327	370	412	455	498	541	583	626	470
250	-	473	533	593	654	714	774	834	994	747
300	-	-	707	787	868	949	1150	1242	1334	1001
350	-	-	-	1007	1244	1364	1483	1602	-	1291

HT BHT	2 100 mm		2 100 mm 1 45 mm	3 100 mm 1 45 mm
----------	------------	--	-------------------------	-------------------------

HT BHT	2 100 mm		2 100 mm 1 45 mm	3 100 mm 1 45 mm
----------	------------	--	-------------------------	-------------------------

BP	2		2	3
DP	-		1	1
BM	8		10	14

BP	2		2	3
DP	-		1	1
BM	8		10	14

The pull-out force refers to the vertical centre to centre measurement between the fixture points of **350 mm**.
In the case of spreader plates a washer conforming to DIN 9021 must be used.

- M = awning width
- H = projection
- FB = pull-out force per fixing point
- HT | BHT = bracket quantity | width
- BP = no. of spreader plates
- DP = no. of spacer plates
- BM = no. of fixing points

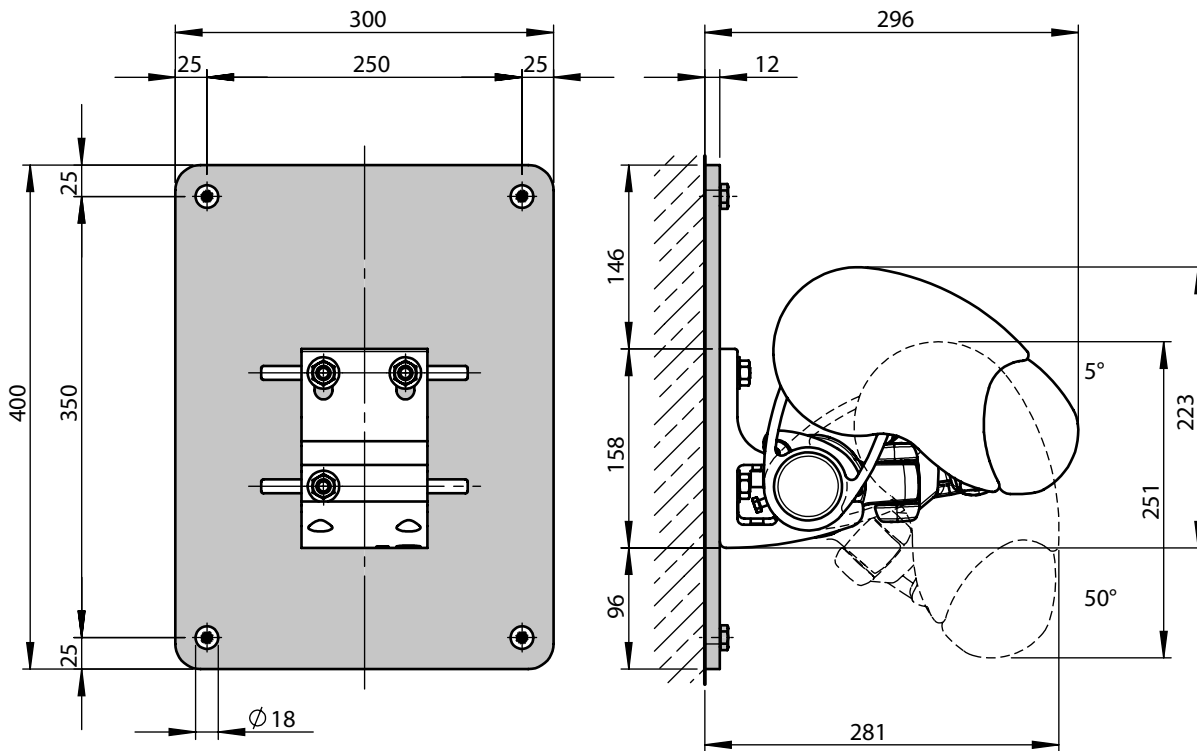

dimensions in mm

Face fixture for shadeplus / drop valance with stand-off brackets

Pull-out force [N=Newton] per upper fixing point according to EN 13561, wind resistance class 2

Compression-proof substrate										Non compression-proof substrate										
M [cm]										M [cm]										
H [cm]										H [cm]										
FB [N]										FB [N]										
260	310	360	410	460	510	560	610	660	710	260	310	360	410	460	510	560	610	660	710	
150	488	560	633	705	777	850	922	994	1066	802	549	630	712	793	874	956	1037	1118	1200	902
200	737	848	959	1069	1180	1291	1402	1512	1623	1220	829	954	1079	1203	1328	1452	1577	1701	1826	1372
250	-	1226	1382	1538	1694	1851	2007	2163	2578	1938	-	1379	1555	1730	1906	2082	2258	2434	2900	2180
300	-	-	1833	2042	2251	2460	2982	3220	3459	2596	-	-	2062	2297	2532	2767	3355	3623	3891	2921
350	-	-	-	2611	3226	3535	3844	4153	-	3346	-	-	-	2937	3630	3977	4325	4672	-	3764
HT BHT	2 100 mm				2 100 mm 1 45 mm			3 100 mm 1 45 mm			2 100 mm				2 100 mm 1 45 mm		3 100 mm 1 45 mm			
DH 77968.	2				2			3			2				2		3			
DH 77967.	-				1			1			-				1		1			
BM	8				12			16			8				12		16			

The pull-out force refers to the vertical centre to centre measurement between the fixture points of **120 mm**.
In the case of stand-off brackets washers conforming to DIN 9021 must be used.

- M = awning width
- H = projection
- FB = pull-out force per fixing point
- HT | BHT = bracket quantity | width
- BM = no. of fixing points
- DH = no. of stand-off brackets
- 77967. = stand-off bracket for face fixture bracket 71813.
- 77968. = stand-off bracket for face fixture bracket 70867.

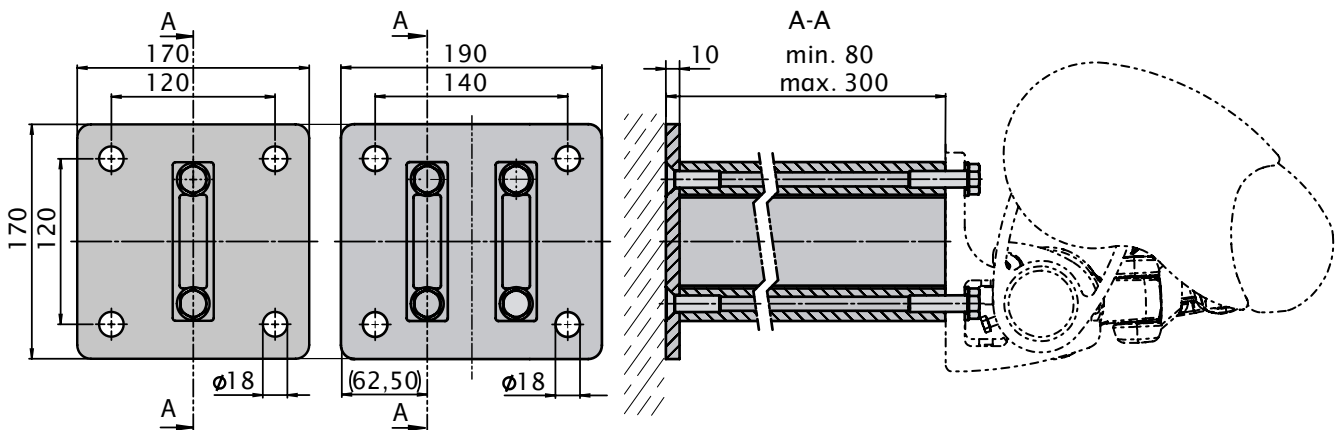
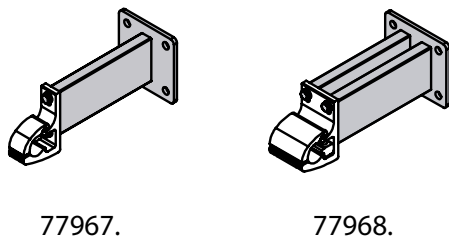

dimensions in mm

01
02
03
04
05
06
07
08
09
10
11
12
13
14
15
16
17
18
19
20
21
22
23

Top fixture

Pull-out force [N=Newton] per upper fixing point according to EN 13561, wind resistance class 2

Compression-proof substrate
M [cm]

	260	310	360	410	460	510	560	610	660	710
H [cm]	FB [N]									
150	594	681	768	855	942	1029	1116	1203	1290	977
200	883	1013	1143	1273	1404	1534	1664	1794	1925	1429
250	-	1460	1643	1826	2009	2191	2374	2557	3069	2244
300	-	-	2179	2423	2668	2912	3557	3839	4121	2994
350	-	-	-	3105	3863	4230	4596	4963	5647	3856
400	-	-	-	-	4846	5308	5770	6233	-	4831

Non compression-proof substrate
M [cm]

	260	310	360	410	460	510	560	610	660	710
	FB [N]									
	759	870	980	1090	1200	1310	1421	1531	1641	1227
	1138	1305	1472	1639	1806	1973	2141	2308	2475	1820
	-	1892	2128	2364	2600	2836	3072	3308	3977	2890
	-	-	2831	3148	3466	3783	4624	4990	5357	3874
	-	-	-	4044	5035	5512	5989	6466	7360	5006
	-	-	-	-	6324	6927	7530	8133	-	6285

HT BHT	2 90 mm	2 90 mm 1 45 mm	3 90 mm 1 45 mm
----------	-----------	------------------------	------------------------

	2 90 mm	2 90 mm 1 45 mm	3 90 mm 1 45 mm
--	-----------	------------------------	------------------------

BM	8	10	14
----	---	----	----

	8	10	14
--	---	----	----

The pull-out force refers to the vertical centre to centre measurement between the fixture points of **80 mm**. If the awning is fitted with two brackets per folding arm the pull-out force may be halved. Place the brackets immediately to the left and right of the arm bearer.

- M = awning width
- H = projection
- FB = pull-out force per fixing point
- HT | BHT = bracket quantity | width
- BM = no. of fixing points
- 70868. = top fixture bracket assembly 90 mm
- 71818. = top fixture bracket assembly 45 mm

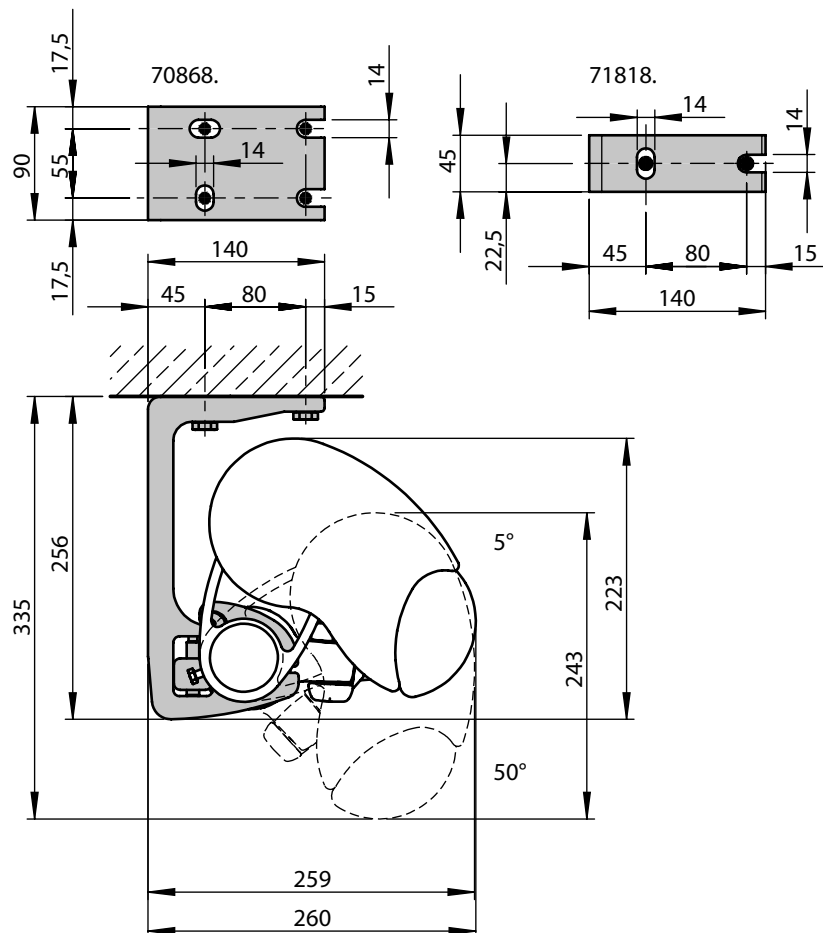

dimensions in mm

Top fixture with shadeplus

Pull-out force [N=Newton] per upper fixing point according to EN 13561, wind resistance class 2

Compression-proof substrate											Non compression-proof substrate											
M [cm]											M [cm]											
H [cm]											H [cm]											
FB [N]											FB [N]											
260	310	360	410	460	510	560	610	660	710		260	310	360	410	460	510	560	610	660	710		
150	685	790	894	999	1103	1207	1312	1416	1521	1197	879	1012	1145	1279	1412	1545	1678	1811	1944	1516		
200	1004	1158	1311	1465	1619	1772	1926	2079	2233	1731	1298	1495	1693	1891	2088	2286	2484	2682	2879	2217		
250	-	1641	1853	2065	2277	2489	2701	2913	3455	2650	-	2130	2404	2679	2953	3227	3502	3776	4483	3422		
300	-	-	2431	2711	2990	3270	3949	4266	4583	3494	-	-	3163	3526	3889	4252	5139	5551	5964	4530		
350	-	-	-	3441	4239	4647	5054	5461	-	4455	-	-	-	4484	5528	6059	6590	7120	-	5792		
HT BHT	2 90 mm					2 90 mm 1 45 mm		3 90 mm 1 45 mm				2 100 mm					2 90 mm 1 45 mm		3 90 mm 1 45 mm			
BM	6					8		11				6					8		11			

The pull-out force refers to the vertical centre to centre measurement between the fixture points of 80 mm. If the awning is fitted with two brackets per folding arm the pull-out force may be halved.

Place the brackets immediately to the left and right of the arm bearer.

- M = awning width
- H = projection
- FB = pull-out force per fixing point
- HT | BHT = bracket quantity | width
- BM = no. of fixing points
- 70868 = top fixture bracket assembly 90 mm
- 71818 = top fixture bracket assembly 45 mm

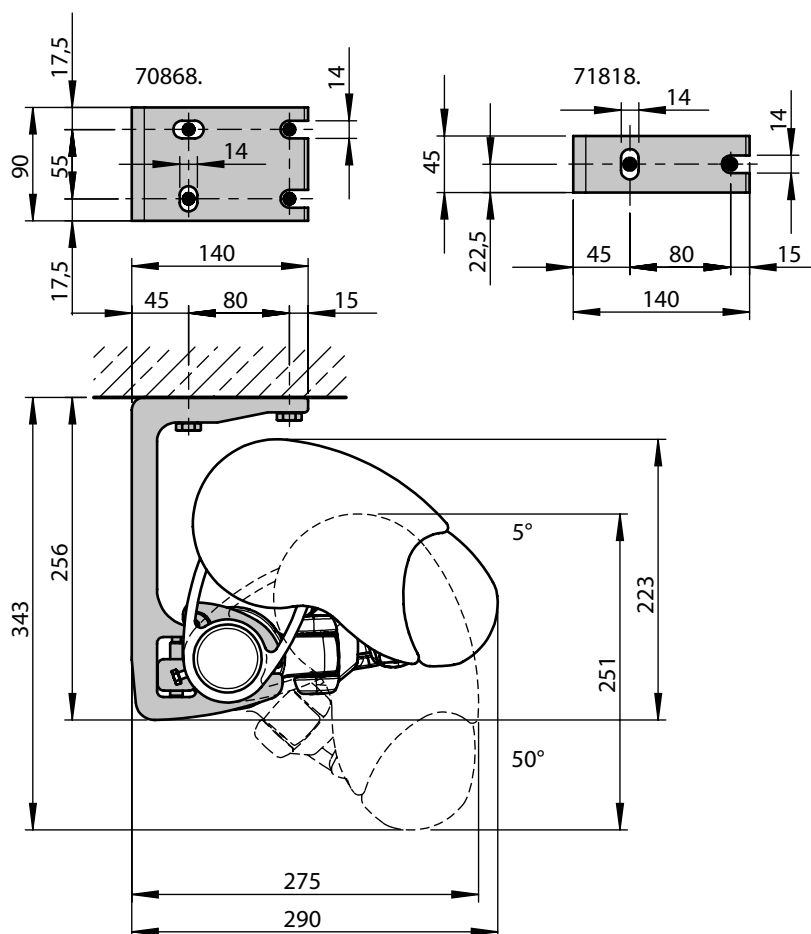

dimensions in mm

Eaves fixture

Torque [Nm = Newton metres] for the fixture bracket in the immediate vicinity of the arm, shear force [N = Newton] per fixing point according to EN 13561, wind resistance class 2

H [cm]	Torque M [cm]										Shear force M [cm]									
	260	310	360	410	460	510	560	610	660	710	260	310	360	410	460	510	560	610	660	710
	Md [Nm]										FS [N]									
150	111	127	142	158	174	189	205	221	236	179	1365	1563	1762	1961	2159	2358	2557	2755	2954	2347
200	172	196	221	246	271	295	320	345	370	280	2038	2338	2637	2937	3237	3537	3836	4136	4436	3465
250	-	290	326	362	398	433	469	505	610	461	-	3381	3804	4226	4649	5071	5493	5916	7106	5479
300	-	-	439	487	536	585	717	774	831	627	-	-	5054	5620	6186	6753	8252	8906	9560	7319
350	-	-	-	631	787	861	936	1010	1151	817	-	-	-	7212	8976	9827	10678	11529	13121	9433
400	-	-	-	-	994	1088	1182	1277	-	1032	-	-	-	-	11269	12343	13418	14492	-	11820
HT	2			3			4				2			3			4			
BM	8			12			16				8			12			16			

The shear force is calculated on the basis of 2 fixing points per bracket, because - depending on the roof pitch - it cannot be guaranteed that 4 fixing points per bracket can be used.

- M = awning width
- H = projection
- Md = torque value for the bracket in the immediate vicinity of the arm
- HT = no. of brackets
- FS = shear force
- BM = no. of fixing points

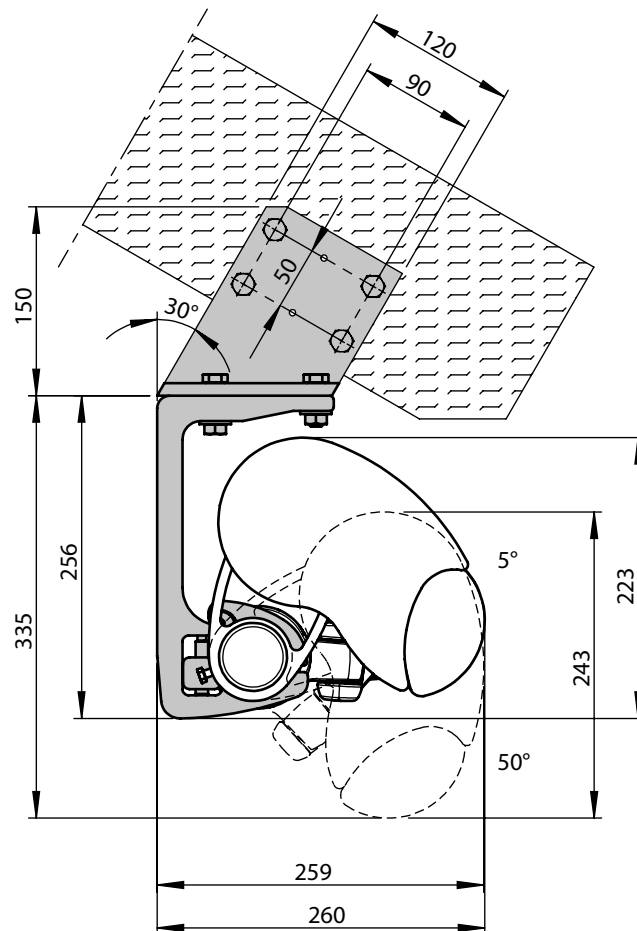

dimensions in mm

Eaves fixture with additional spreader / backing plate

Torque [Nm = Newton metres] for the fixture bracket in the immediate vicinity of the arm, shear force [N = Newton] per fixing point according to EN 13561, wind resistance class 2

H [cm]	Torque M [cm]										Shear force M [cm]									
	260	310	360	410	460	510	560	610	660	710	260	310	360	410	460	510	560	610	660	710
	Md [Nm]										FS [N]									
150	111	127	142	158	174	189	205	221	236	179	686	789	892	995	1098	1201	1304	1408	1511	1251
200	172	196	221	246	271	295	320	345	370	280	989	1137	1286	1434	1583	1732	1880	2029	2178	1754
250	-	290	326	362	398	433	469	505	610	461	-	1607	1811	2015	2218	2422	2626	2830	3379	2661
300	-	-	439	487	536	585	717	774	831	627	-	-	2373	2642	2910	3179	3867	4175	4483	3489
350	-	-	-	631	787	861	936	1010	1151	817	-	-	-	3358	4166	4562	4959	5356	6086	4440
400	-	-	-	-	994	1088	1182	1277	-	1032	-	-	-	-	5198	5695	6192	6689	-	5514
HT	2				3			4			2				3			4		
BM	4				6			8			4				6			8		

By using the additional flat fixture plate, the shear force is reduced in comparison with conventional eaves fixture.

- M = awning width
- H = projection
- Md = torque value for the bracket in the immediate vicinity of the arm
- HT = no. of brackets
- FS = shear force
- BM = no. of fixing points

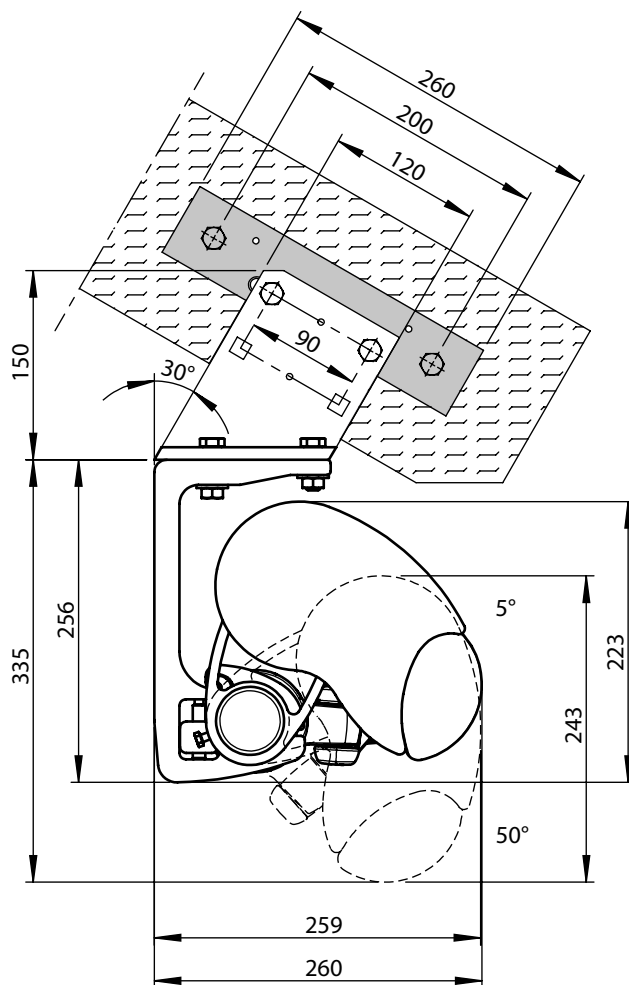

dimensions in mm

- 01
- 02
- 03
- 04
- 05
- 06
- 07
- 08
- 09
- 10
- 11
- 12
- 13
- 14
- 15
- 16
- 17
- 18
- 19
- 20
- 21
- 22
- 23

Installation using the adjustable eaves fixture bracket

Pull-out force [N=Newton] per upper fixing point according to EN 13561, wind resistance class 2

Compression-proof substrate
M [cm]

Non compression-proof substrate
M [cm]

		Compression-proof substrate										Non compression-proof substrate									
		M [cm]										M [cm]									
		260	310	360	410	460	510	560	610	660	710	260	310	360	410	460	510	560	610	660	710
H [cm]	FB [N]																				
150	896	1029	1162	1295	1427	1560	1693	1826	1959	1513	924	1060	1197	1334	1470	1607	1743	1880	2017	1554	
200	1314	1510	1705	1901	2096	2292	2487	2683	2879	2168	1357	1558	1760	1961	2163	2365	2566	2768	2970	2232	
250	-	2158	2429	2701	2973	3244	3516	3787	4536	3348	-	2229	2510	2790	3070	3351	3631	3912	4686	3455	
300	-	-	3205	3566	3927	4288	5228	5643	6059	4434	-	-	3313	3686	4059	4432	5405	5834	6263	4580	
350	-	-	-	4554	5659	6196	6734	7271	8269	5683	-	-	-	4709	5852	6408	6964	7520	8553	5873	
400	-	-	-	-	7082	7758	8434	9111	-	7094	-	-	-	-	7326	8026	8726	9425	-	7335	

HT BHT	Compression-proof substrate			Non compression-proof substrate		
	2 90 mm	2 90 mm 1 45 mm	3 90 mm 1 45 mm	2 90 mm	2 90 mm 1 45 mm	3 90 mm 1 45 mm

BM	Compression-proof substrate			Non compression-proof substrate		
	8	10	14	8	10	14

The pull-out force refers to the measurement from the front to the rear fixture points of **140 mm**.

Washers conforming to DIN 9021 must be used.

- M = awning width
- H = projection
- FB = pull-out force per fixing point
- HT | BHT = bracket quantity | width
- BM = no. of fixing points

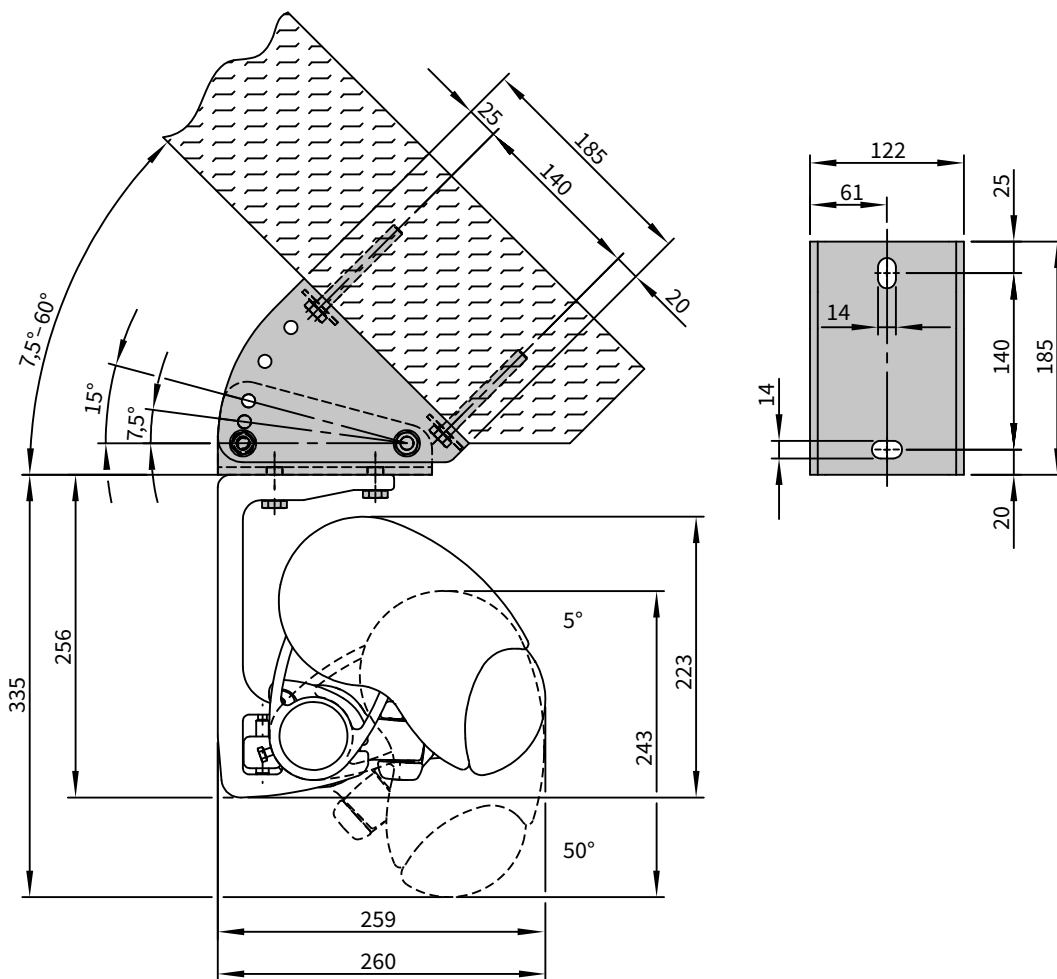

dimensions in mm

Installation with shadeplus using the adjustable eaves fixture bracket

Pull-out force [N=Newton] per upper fixing point according to EN 13561, wind resistance class 2

Compression-proof substrate											Non compression-proof substrate													
M [cm]											M [cm]													
H [cm]											H [cm]													
FB [N]											FB [N]													
260	310	360	410	460	510	560	610	660	710		260	310	360	410	460	510	560	610	660	710				
150	1028	1186	1345	1503	1661	1819	1977	2135	2293	1832	1060	1223	1386	1549	1712	1875	2038	2201	2364	1884				
200	1490	1720	1949	2178	2408	2637	2866	3096	3325	2606	1539	1775	2012	2249	2485	2722	2959	3195	3432	2686				
250	-	2420	2734	3048	3362	3675	3989	4303	5094	3935	-	2501	2825	3149	3473	3798	4122	4446	5264	4063				
300	-	-	3570	3982	4394	4806	5796	6262	6728	5158	-	-	3691	4117	4543	4968	5994	6475	6957	5330				
350	-	-	-	5039	6203	6800	7397	7994	-	6550	-	-	-	5212	6417	7034	7651	8268	-	6771				
HT BHT	2 90 mm					2 90 mm		3 90 mm			2 90 mm					2 90 mm		3 90 mm						
						1 45 mm		1 45 mm								1 45 mm		1 45 mm						
BM	8				10			14					8				10			14				

The pull-out force refers to the measurement from the front to the rear fixture points of 140 mm.

Washers conforming to DIN 9021 must be used.

- M = awning width
- H = projection
- FB = pull-out force per fixing point
- HT | BHT = bracket quantity | width
- BM = no. of fixing points

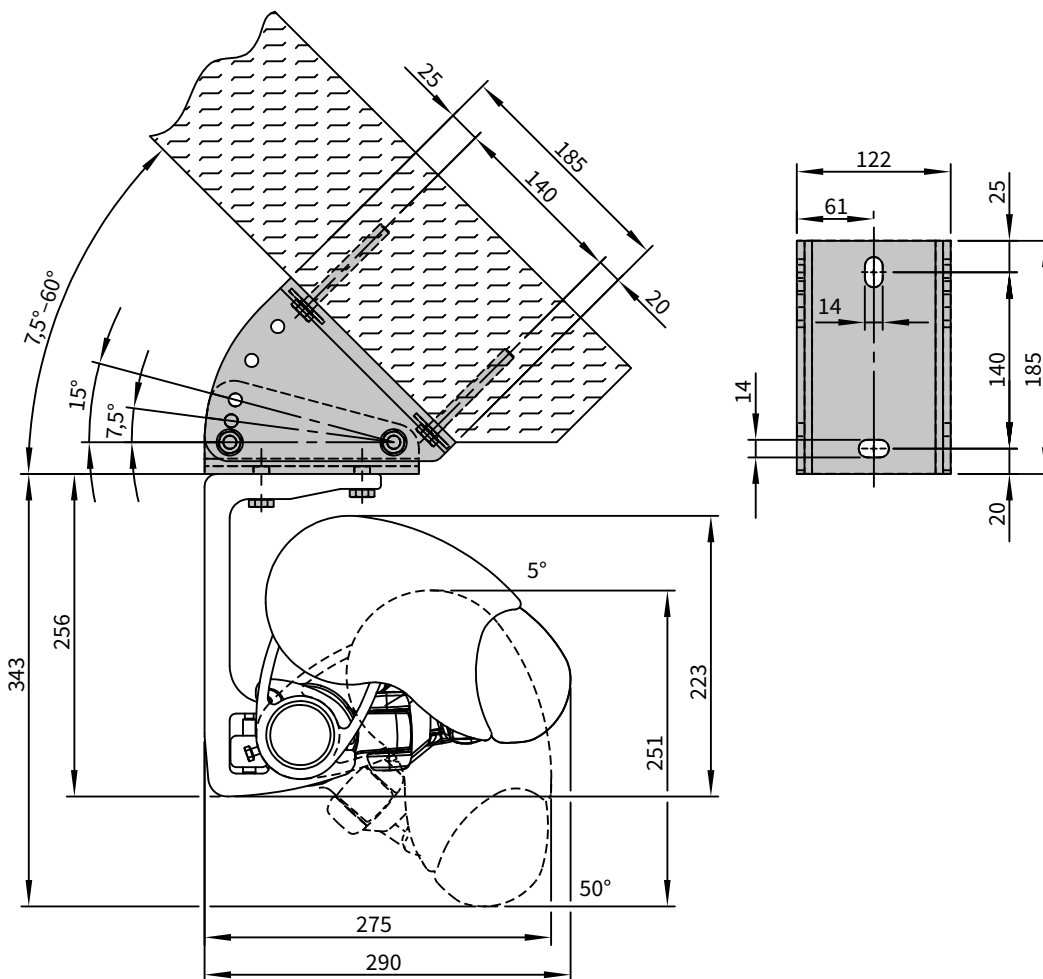

dimensions in mm

- 01
- 02
- 03
- 04
- 05
- 06
- 07
- 08
- 09
- 10
- 11
- 12
- 13
- 14
- 15
- 16
- 17
- 18
- 19
- 20
- 21
- 22
- 23

Face fixture with manual operation

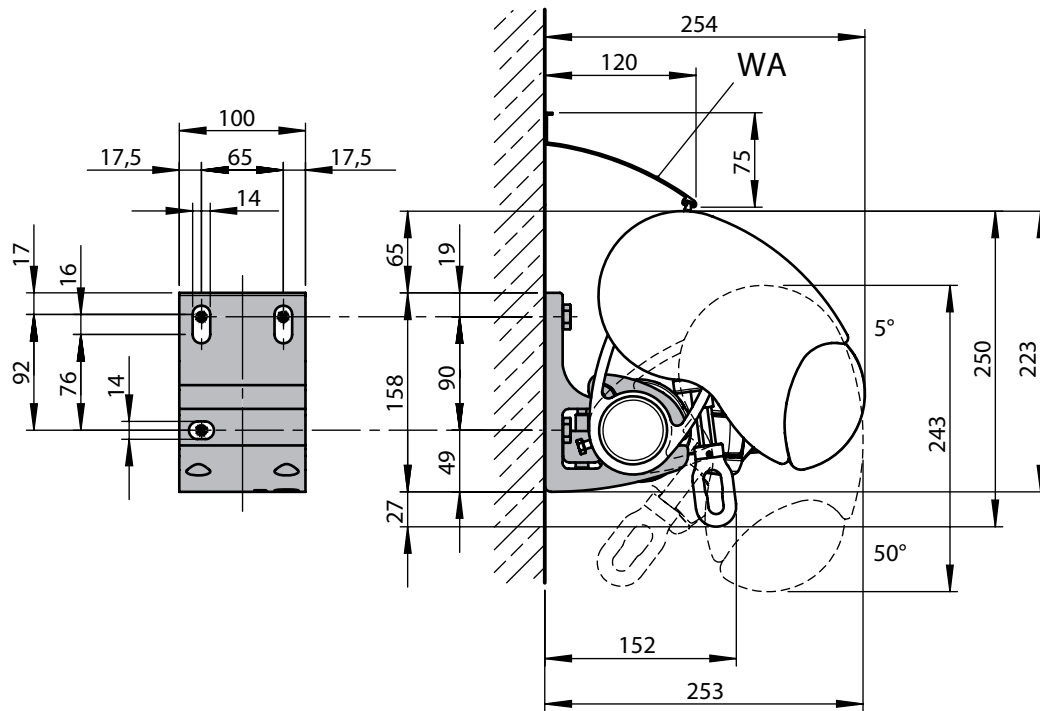

dimensions in mm

Cable exit position on motor-driven units

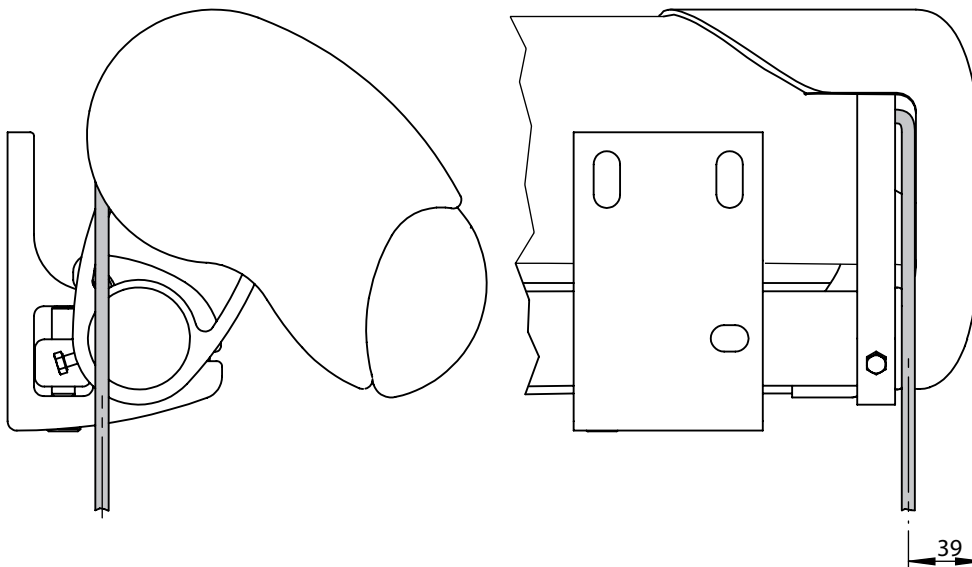

dimensions in mm

Dimensions at different awning pitches

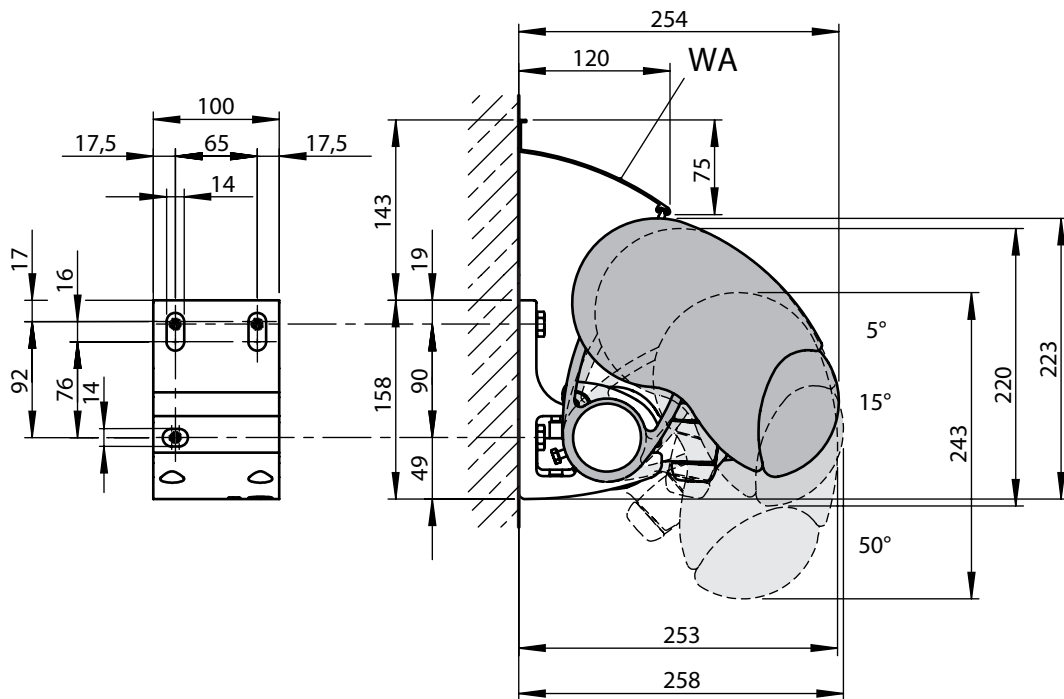

WA = wall sealing profile

dimensions in mm

- 01
- 02
- 03
- 04
- 05
- 06
- 07
- 08
- 09
- 10
- 11**
- 12
- 13
- 14
- 15
- 16
- 17
- 18
- 19
- 20
- 21
- 22
- 23

Bracket fixture range for awnings with 2 folding arms

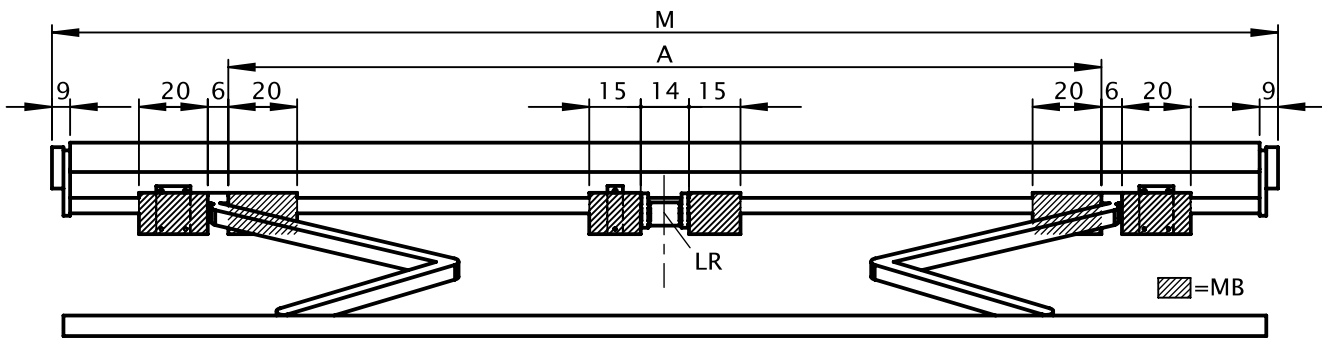

M [cm]	SB →	260	310	360	410	460	510	560	610	660
	ZB →	174–260	261–310	311–360	361–410	411–460	461–510	511–560	561–610	611–660

H [cm] ↓	A [cm]								
150	154*	220	250	280	320	390	425	460	500
200	204**	204*	250	280	320	390	425	460	500
250	-	254**	254*	280	320	390	425	460	500
300	-	-	304**	304*	320	390	425	460	500
350	-	-	-	354**	370*	390	425	460	500
400	-	-	-	-	404**	425*	425	460	-

dimensions in cm

W	BHT ↓	HT ↓	
	45 mm	-	1
100 mm	2	2	

DE	45 mm	-	1
	90 mm	2	2

DA	90 mm	2	3
----	-------	---	---

If the brackets cannot be positioned in accordance with this table, make sure the actual measurements are noted on the order form!

- * = Coupled units are only available with a junction roller in the standard widths, in the case of other widths please ask us.
- ** = Please note the minimum widths! Dimension **A** is only valid for standard arms! Dimension **A** is 13 cm smaller in the case of bespoke arms in the case of small awnings the brackets can only be fitted inside the arms, i.e. the position denoted by measurement **A**.

- A = arm position
- BHT = bracket width
- DA = eaves fixture
- DE = top fixture
- GS = cassette support bracket
- H = projection
- HT = no. of brackets
- LR = a rolltex bearing with accompanying bracket is always placed under a central seam (depends on the awning size)
- M = awning width
- MB = bracket fixture range
- SB = standard width
- W = face fixture
- ZB = intermediate width

Bracket fixture range for awnings with 3 folding arms

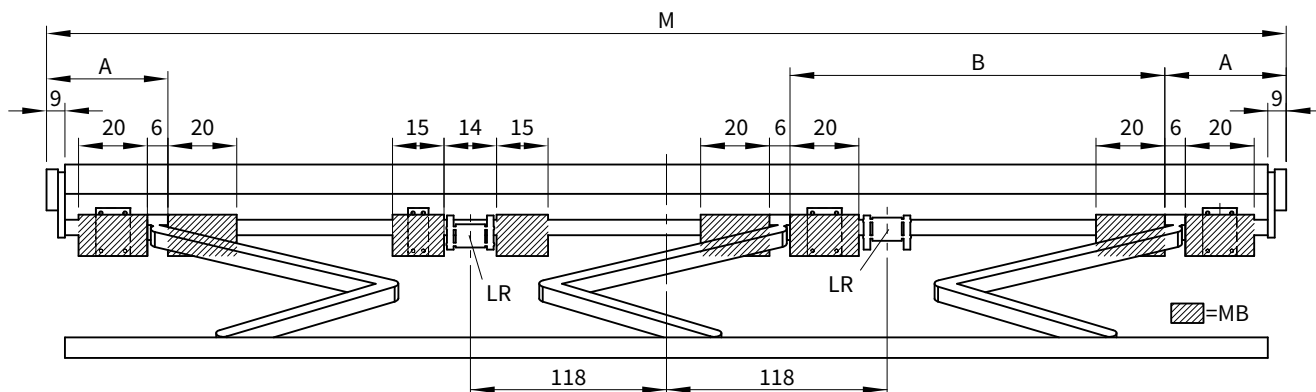

M [cm]	SB →	710
	ZB →	661–710

H [cm] ↓	A [cm] ↓	B [cm] ↓
150	35	220
200	35	220
250	35	220
300	35	220
350	25	230
400	17*	229*

dimensions in cm

W	BHT ↓	HT ↓
	45 mm	1
100 mm	3	

DE	45 mm	1
	90 mm	3

DA	90 mm	4
----	-------	---

If the brackets cannot be positioned in accordance with this table, make sure the actual measurements are noted on the order form!

* = Please note the minimum widths, dimension **A** is only valid for standard arms! coupled units are not available with junction roller.

A = arm position

B = arm position

BHT = bracket width

DA = eaves fixture

DE = top fixture

H = projection

HT = no. of brackets

LR = a rolltex bearing with accompanying bracket is always placed under a central seam (depends on the awning size)

M = awning width

MB = bracket fixture range

SB = standard width

W = face fixture

ZB = intermediate width

- 01
- 02
- 03
- 04
- 05
- 06
- 07
- 08
- 09
- 11
- 12
- 13
- 14
- 15
- 16
- 17
- 18
- 19
- 20
- 21
- 22
- 23

Installation dimensions at varying awning pitches

Top fixture

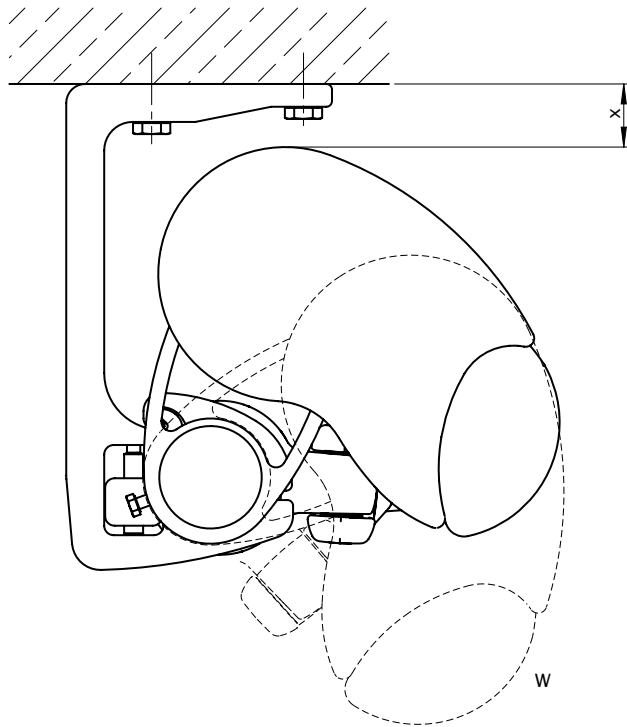

pitch (W)	approx. height in mm (X)
5°	33
10°	34
15°	38
20°	44
25°	50
30°	57
35°	65
40°	73
45°	81
50°	90

Face fixture

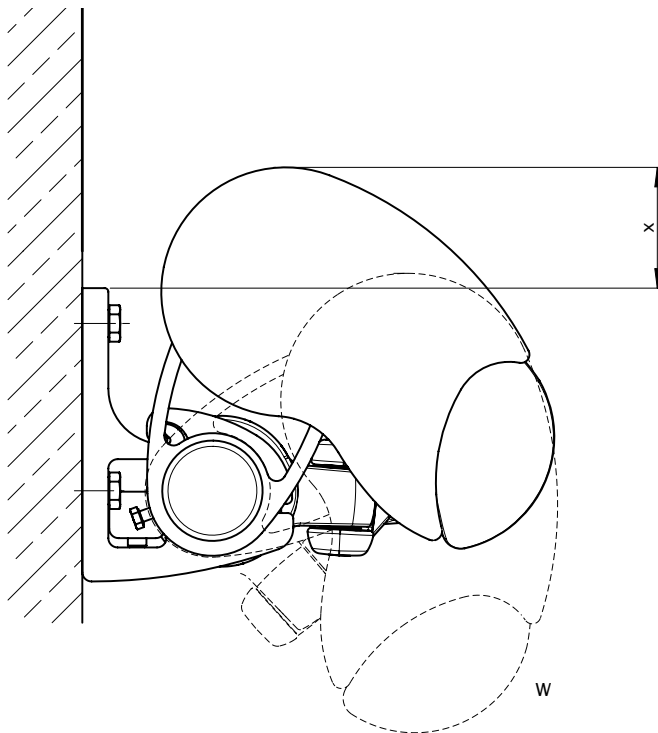

pitch (W)	approx. height in mm (X)
5°	65
10°	64
15°	60
20°	54
25°	48
30°	41
35°	34
40°	26
45°	17
50°	8