

markilux 1710 stretch

Chic, modern, compact – the cover cassette awning with perfected design features. The perfect solution for narrow patios, niches and balconies

**rated to wind resistance class 2
(corresponds to Beaufort 5)**



reddot design award
winner 2012

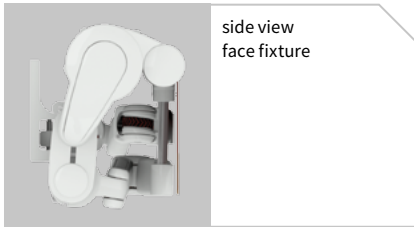

side view
face fixture

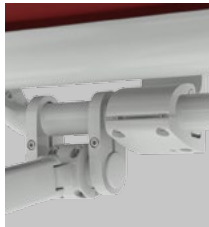

tiered folding arm
fitted to the sturdy
torque bar



pitch adjustment
from 5° to 25°
via the fixture brackets

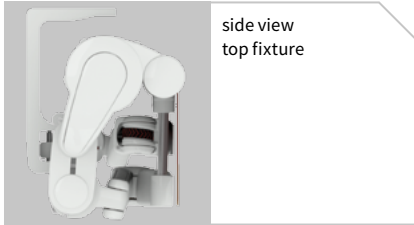

side view
top fixture



arm connection
to the front profile



side view
with wall sealing profile
(optional), effective
up to a maximum
awning pitch of 15°

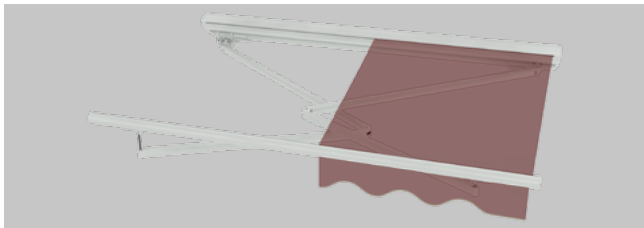

greater projection
than width: the perfect
solution for narrow
patios, niches and
balconies; arms cross
above one another
during extension
and retraction

Design Features

cover cassette made of extruded aluminium; a compact cassette combined with proven technology to enable the safe shading of larger areas

the special cassette shape surrounds the roller tube even when the awning is extended thus creating an overall harmonious appearance

the transition from torque bar to roller tube is curved and homogeneous

side caps available in polished chrome offer an optional designer touch

Technical Specification

thanks to this innovative technical solution – tiered arms – large projections can still be achieved in narrow awnings

attractive front profile made of extruded aluminium with integrated gutter and water drainage spouts

sturdy, round steel torque bar, 50 mm Ø, to prevent twist and deflection

the 85 mm roller tube ensures the highest rigidity and the best possible cover winding characteristics even at the largest widths

unique arm technology with power transference by way of the highly tear-resistant bionic tendon made of high-tech fibres, achieving at least 50,000 cycles in tests by the Fraunhofer Institute

Optional Accessories

hard-wired motor operation (optionally with automatic weather controls) for straightforward and easy operation

radio-controlled motor with radio remote control for ease of use

in the case of manual operation ease of use is ensured with the spring-assisted gearbox

wall sealing profile to cover the gap between awning and wall

awning available in non-standard RAL colours

markilux infrared heater in a compact aluminium housing; caressing warmth without heating-up phase within an area of approx. 9-12 m²

Lounge colours

markilux 1710 stretch

off-white textured finish 5233

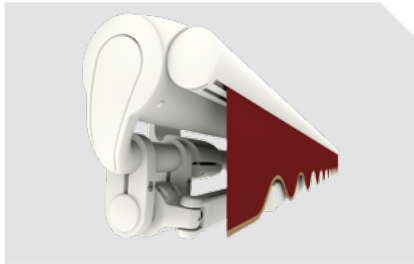

stone grey metallic 5215

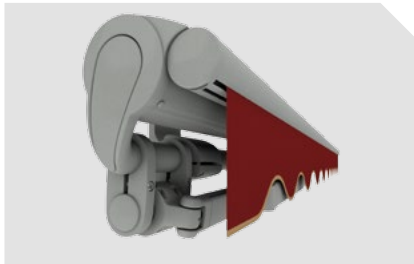

Havana brown textured finish 5229



anthracite metallic 5204



End caps in polished chrome

off-white textured finish 5233

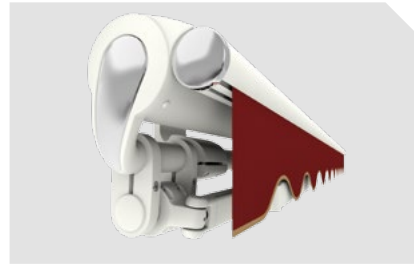

stone grey metallic 5215

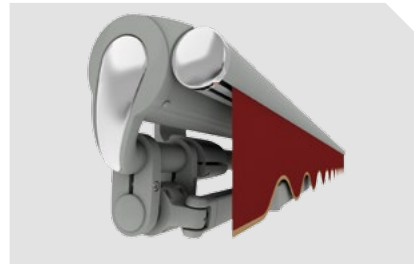

Havana brown textured finish 5229

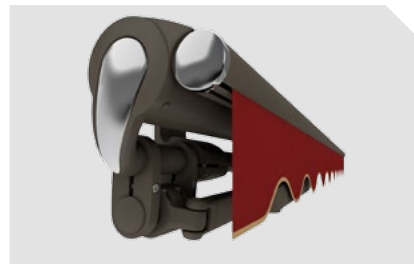

anthracite metallic 5204



- 01
- 02
- 03
- 04
- 05
- 06
- 07
- 08
- 09
- 10
- 11
- 12
- 13
- 14
- 15
- 16
- 17
- 18
- 19
- 20
- 21
- 22
- 23

Colours may differ slightly from those depicted in both hue and finish.

Dimensions and configuration options

		150	175	200	225	250	300	350				
		123 150	151 175	176 200	201 225	226 250	251 300	301 350				
	150	2)		1)	-	-	-	-	130	123	132	125
	200	-	2)			1)	-	-	155	148	157	150
	250	-	-	2)			1)	-	180	173	182	175
	300	-	-	2)				1)	205	198	207	200
	350	-	-	-	2)				230	223	232	225

dimensions in cm

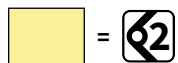

- 1) intermediate widths on request
- 2) please note the minimum widths!

Operation / Drive

	standard	optional
manual operation	<input checked="" type="checkbox"/>	-
servo-assisted operation	-	<input checked="" type="checkbox"/>
hard-wired motor	-	<input checked="" type="checkbox"/>
io radio controls	-	<input checked="" type="checkbox"/>
radio-controlled motor (433 MHz)	-	<input checked="" type="checkbox"/>

Covers

	fabric range no.	standard	optional
sunsilk snc	324 .. / 328 .. / 369 ..	<input checked="" type="checkbox"/>	-
sunsilk perla FR	374 ..	-	<input checked="" type="checkbox"/>
sunvas snc	310 .. / 311 .. 313 .. — 315 ..	<input checked="" type="checkbox"/>	-
sunvas perla	370 xx	-	<input checked="" type="checkbox"/>

Miscellaneous

	standard	optional
bionic tendon	<input checked="" type="checkbox"/>	-
wall sealing profile	-	<input checked="" type="checkbox"/> ³⁾
light and wind sensor	-	<input checked="" type="checkbox"/>
valance	<input checked="" type="checkbox"/> ⁴⁾	-
infrared heater	-	<input checked="" type="checkbox"/>
vibrabox / radio control light sensor Sunis WireFree	-	<input checked="" type="checkbox"/>





Dimensions and tolerances

	width		projection
housing tolerances	+5 / -10 mm		±40 mm
awning cover width = awning width	-100 mm	-135 mm	
awning cover length = awning projection			+150 mm

- 3) up to a maximum awning pitch of 15°
- 4) valance shape 2 (please refer to the section “markilux Collection”)

= motor	= manual operation	M = awning width
= no. of folding arms	= no. of bespoke arms	M min. = minimum widths
		H = projection

Frame colours

		standard	optional
traffic white	RAL 9016		
metallic aluminium	RAL 9006		
grey brown, similar to	RAL 8019		
light ivory	RAL 1015		
anthracite metallic	5204		
stone grey metallic	5215		
off-white textured finish	5233		
Havana brown textured finish	5229		
non-standard powder-coated finish			

Other end cap colour options

	standard	optional
polished chrome		

Additional information

The width of the awning cover is always **less** than that of the awning.

Definition of operation side:

The operation side is given looking at the awning from the outside (right or left)

Pitch adjustment range:

from 5° to 25° (to the horizontal).

Definition of projection:

please consult the “Technical Information” section.

In the case of manual operation approximately **16 winding handle revolutions can be assumed per metre of awning projection.**

It takes approximately **12 seconds per metre** to extend the awning in the case of **motor-driven units.**

This model is only available as a single unit.

Colours similar to those in the RAL chart. Colours may differ slightly from those depicted in both hue and finish.

01
02
03
04
05
06
07
08
09
10
11
12
13
14
15
16
17
18
19
20
21
22
23

Fixtures, fittings and accessories

Fixture brackets

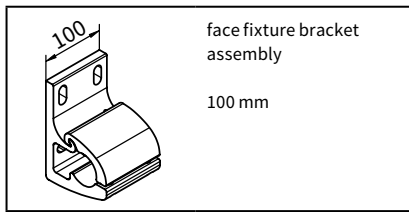

face fixture bracket assembly
100 mm

70867.

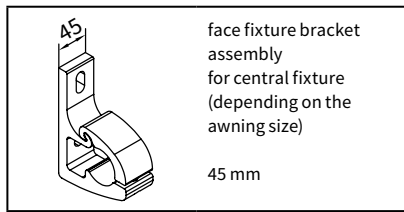

face fixture bracket assembly for central fixture (depending on the awning size)
45 mm

71813.

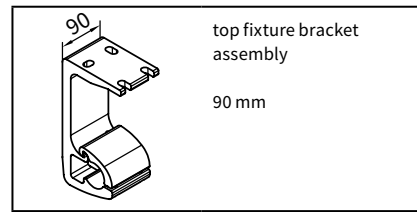

top fixture bracket assembly
90 mm

70868.

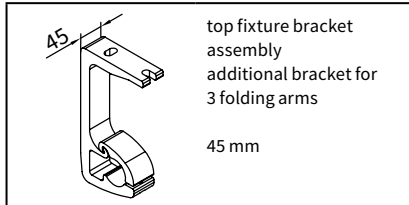

top fixture bracket assembly additional bracket for 3 folding arms
45 mm

71818.

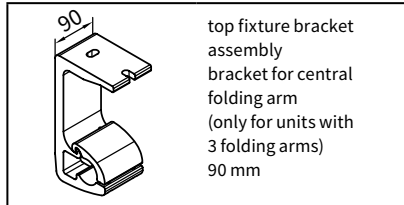

top fixture bracket assembly bracket for central folding arm (only for units with 3 folding arms)
90 mm

70869.

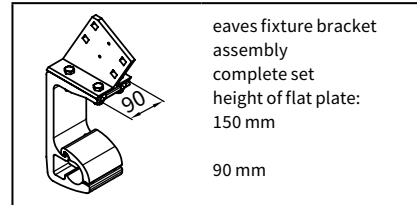

eaves fixture bracket assembly complete set height of flat plate: 150 mm
90 mm

70871.

Spreader and spacer plates

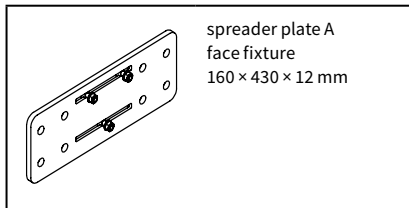

spreader plate A face fixture
160 x 430 x 12 mm

75326.

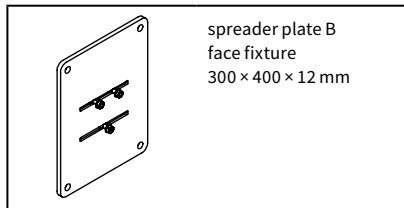

spreader plate B face fixture
300 x 400 x 12 mm

75325.

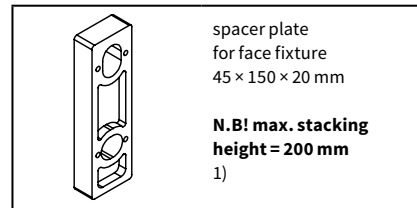

spacer plate for face fixture
45 x 150 x 20 mm

N.B! max. stacking height = 200 mm
1)

718251

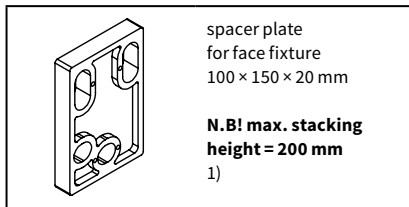

spacer plate for face fixture
100 x 150 x 20 mm

N.B! max. stacking height = 200 mm
1)

718231

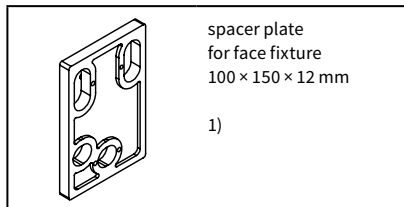

spacer plate for face fixture
100 x 150 x 12 mm

1)

718241

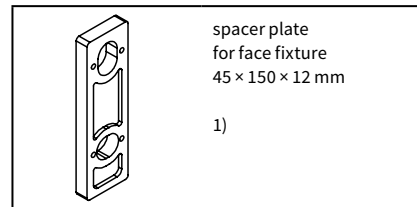

spacer plate for face fixture
45 x 150 x 12 mm

1)

71826.

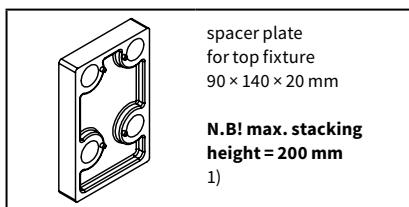

spacer plate for top fixture
90 x 140 x 20 mm

N.B! max. stacking height = 200 mm
1)

716311

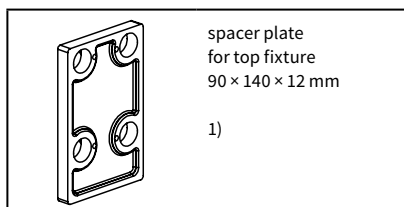

spacer plate for top fixture
90 x 140 x 12 mm

1)

716411

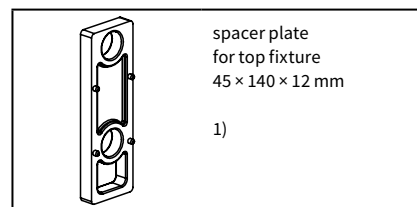

spacer plate for top fixture
45 x 140 x 12 mm

1)

716371

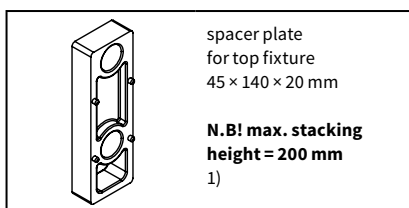

spacer plate for top fixture
45 x 140 x 20 mm

N.B! max. stacking height = 200 mm
1)

716261

1) please refer to the section "Technical Information"

. = insert RAL colour code no

01
02
03
04
05
06
07
08
09
10
11
12
13
14
15
16
17
18
19
20
21
22
23

Stand-off brackets

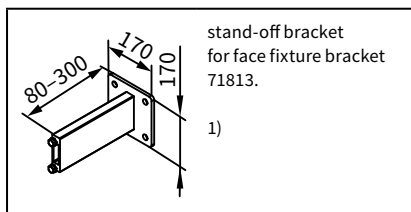

stand-off bracket for face fixture bracket 71813.

1)

77967.

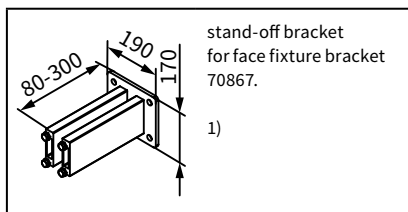

stand-off bracket for face fixture bracket 70867.

1)

77968.

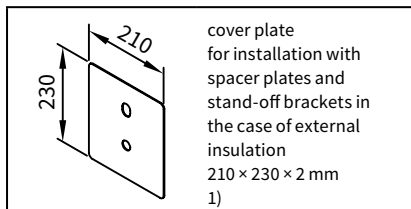

cover plate for installation with spacer plates and stand-off brackets in the case of external insulation

210 × 230 × 2 mm

1)

71844.

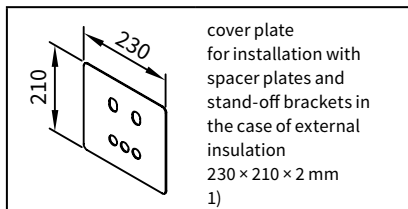

cover plate for installation with spacer plates and stand-off brackets in the case of external insulation

230 × 210 × 2 mm

1)

71843.

Accessories

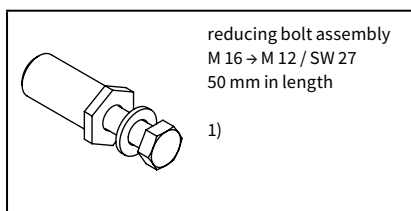

reducing bolt assembly M 16 → M 12 / SW 27 50 mm in length

1)

753891

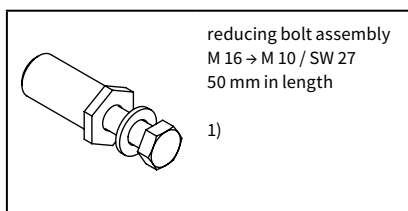

reducing bolt assembly M 16 → M 10 / SW 27 50 mm in length

1)

754921

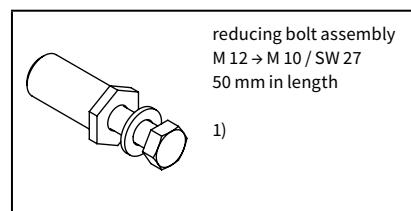

reducing bolt assembly M 12 → M 10 / SW 27 50 mm in length

1)

754911

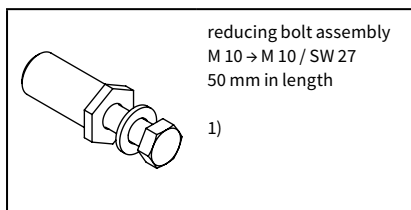

reducing bolt assembly M 10 → M 10 / SW 27 50 mm in length

1)

754901

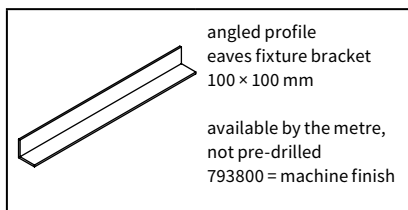

angled profile eaves fixture bracket 100 × 100 mm

available by the metre, not pre-drilled 793800 = machine finish

79380.

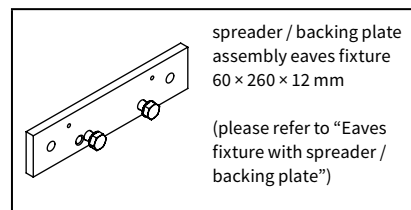

spreader / backing plate assembly eaves fixture 60 × 260 × 12 mm

(please refer to "Eaves fixture with spreader / backing plate")

75383.

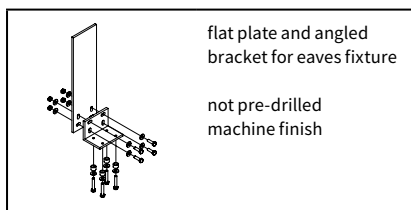

flat plate and angled bracket for eaves fixture

not pre-drilled machine finish

716620

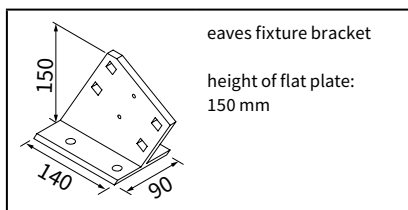

eaves fixture bracket

height of flat plate: 150 mm

71612.

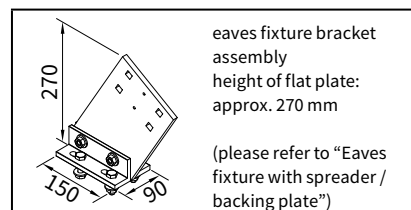

eaves fixture bracket assembly height of flat plate: approx. 270 mm

(please refer to "Eaves fixture with spreader / backing plate")

71659.

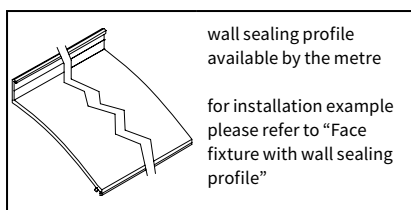

wall sealing profile available by the metre

for installation example please refer to "Face fixture with wall sealing profile"

77780.

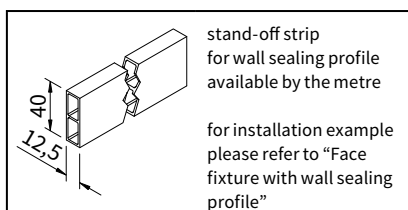

stand-off strip for wall sealing profile available by the metre

for installation example please refer to "Face fixture with wall sealing profile"

751971

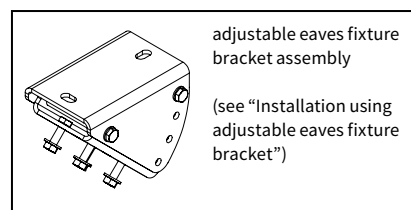

adjustable eaves fixture bracket assembly

(see "Installation using adjustable eaves fixture bracket")

71198.

1) please refer to the section "Technical Information"

. = insert RAL colour code no

Face fixture

Pull-out force [N=Newton] per upper fixing point according to EN 13561, wind resistance class 2

Compression-proof substrate
M [cm]

150	175	200	225	250	300	350	400
-----	-----	-----	-----	-----	-----	-----	-----

Non compression-proof substrate
M [cm]

150	175	200	225	250	300	350	400
-----	-----	-----	-----	-----	-----	-----	-----

H [cm]	FB [N]							
150	270	297	-	-	-	-	-	-
200	-	504	548	592	-	-	-	-
250	-	-	783	848	912	-	-	-
300	-	-	-	1147	1236	1413	-	-
350	-	-	-	-	1669	1902	2135	-

H [cm]	FB [N]							
150	387	426	-	-	-	-	-	-
200	-	722	785	849	-	-	-	-
250	-	-	1123	1215	1308	-	-	-
300	-	-	-	1644	1771	2025	-	-
350	-	-	-	-	2392	2726	3061	-

HT BHT	2 100 mm
----------	------------

HT BHT	2 100 mm
----------	------------

BM	6
----	---

BM	6
----	---

The pull-out force refers to the vertical centre to centre measurement between the fixture points of **90 mm**. If this measurement is reduced to the minimum, the pull-out force increases by **14%** in the case of **compression-proof substrates** and by **19%** in the case of **non compression-proof substrates**.

- M = awning width
- H = projection
- FB = pull-out force per fixing point
- HT | BHT = bracket quantity | width
- BM = no. of fixing points
- WA = wall sealing profile
- 70867. = face fixture bracket assembly 100 mm

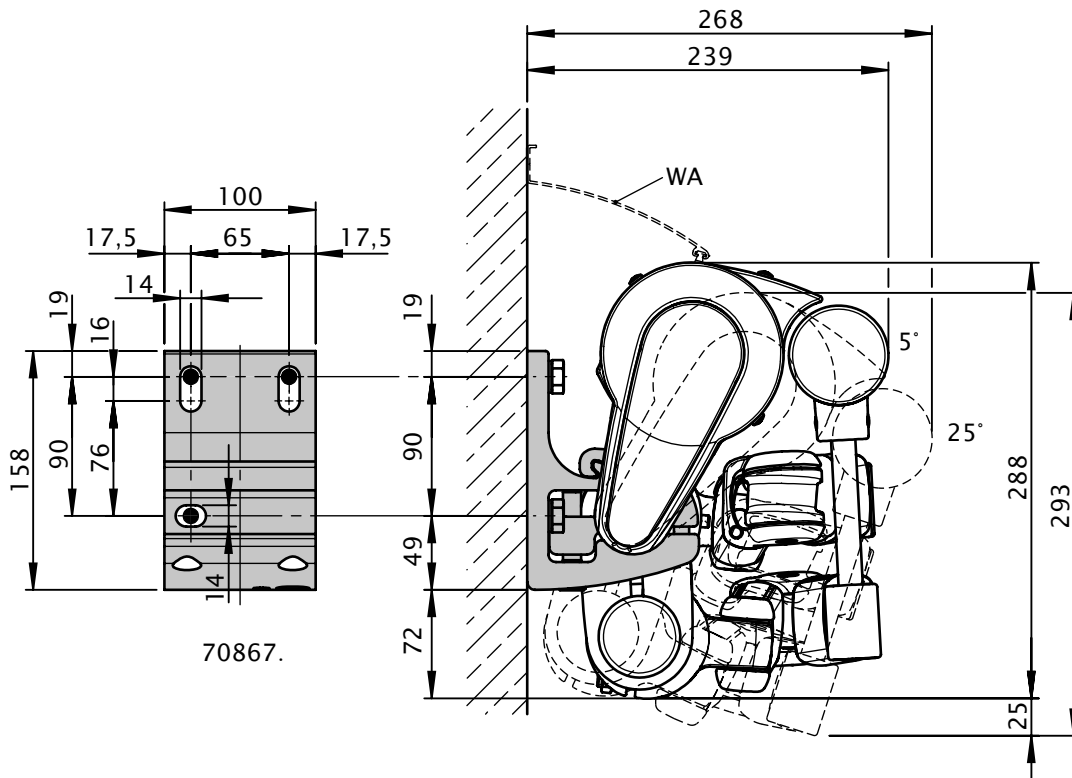

dimensions in mm

Face fixture with spreader plate A

Pull-out force [N=Newton] per upper fixing point according to EN 13561, wind resistance class 2

Compression-proof substrate									Non compression-proof substrate								
M [cm]									M [cm]								
H [cm]									H [cm]								
FB [N]									FB [N]								
	150	175	200	225	250	300	350	400		150	175	200	225	250	300	350	400
150	179	198	-	-	-	-	-	-	255	281	-	-	-	-	-	-	-
200	-	328	357	386	-	-	-	-	-	466	508	549	-	-	-	-	-
250	-	-	504	546	588	-	-	-	-	-	716	775	835	-	-	-	-
300	-	-	-	731	788	902	-	-	-	-	-	1039	1120	1282	-	-	-
350	-	-	-	-	1056	1204	1353	-	-	-	-	-	1500	1711	1923	-	-
HT BHT	2 100 mm								2 100 mm								
BP	2								2								
BM	16								16								

The pull-out force refers to the vertical centre to centre measurement between the fixture points of 76 mm. In the case of spreader plates washers conforming to DIN 9021 must be used.

- M = awning width
- H = projection
- FB = pull-out force per fixing point
- HT | BHT = bracket quantity | width
- BP = no. of spreader plates
- BM = no. of fixing points
- WA = wall sealing profile
- 751971 = stand-off strip for wall sealing profile

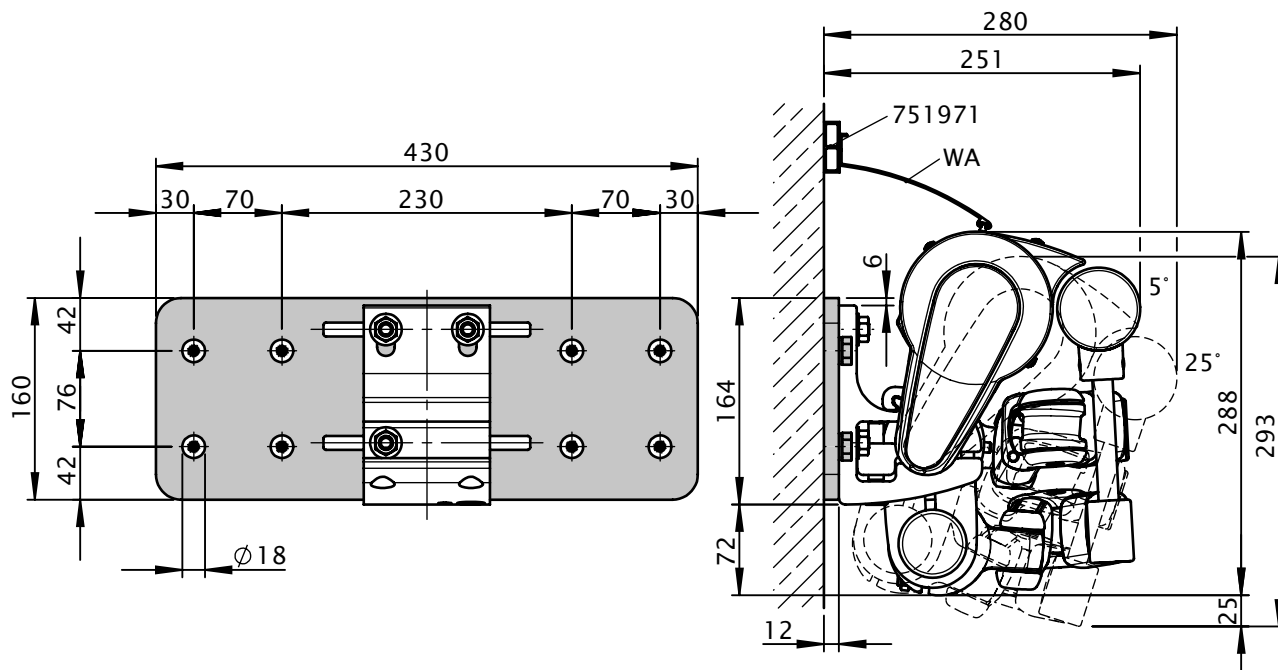

dimensions in mm

- 01
- 02
- 03
- 04
- 05
- 06
- 07
- 08
- 09
- 10
- 11
- 12
- 13
- 14
- 15
- 16
- 17
- 18
- 19
- 20
- 21
- 22
- 23

Face fixture with stand-off brackets

Pull-out force [N=Newton] per upper fixing point according to EN 13561, wind resistance class 2

Compression-proof substrate									Non compression-proof substrate								
M [cm]									M [cm]								
H [cm]									H [cm]								
FB [N]									FB [N]								
150	175	200	225	250	300	350	400		150	175	200	225	250	300	350	400	
150	342	376	-	-	-	-	-	-	385	423	-	-	-	-	-	-	-
200	-	604	656	709	-	-	-	-	-	680	738	797	-	-	-	-	-
250	-	-	904	978	1052	-	-	-	-	-	1017	1100	1183	-	-	-	-
300	-	-	-	1289	1388	1586	-	-	-	-	-	1450	1562	1785	-	-	-
350	-	-	-	-	1839	2095	2351	-	-	-	-	-	2069	2357	2645	-	-
HT BHT	2 100 mm								2 100 mm								
DH 77968.	2								2								
BM	8								8								

The pull-out force refers to the vertical centre to centre measurement between the fixture points of **120 mm**. In the case of stand-off brackets washers conforming to DIN 9021 must be used.

- M = awning width
- H = projection
- FB = pull-out force per fixing point
- HT | BHT = bracket quantity | width
- BM = no. of fixing points
- DH = no. of stand-off brackets
- 77968. = stand-off bracket for face fixture bracket assembly 70867.

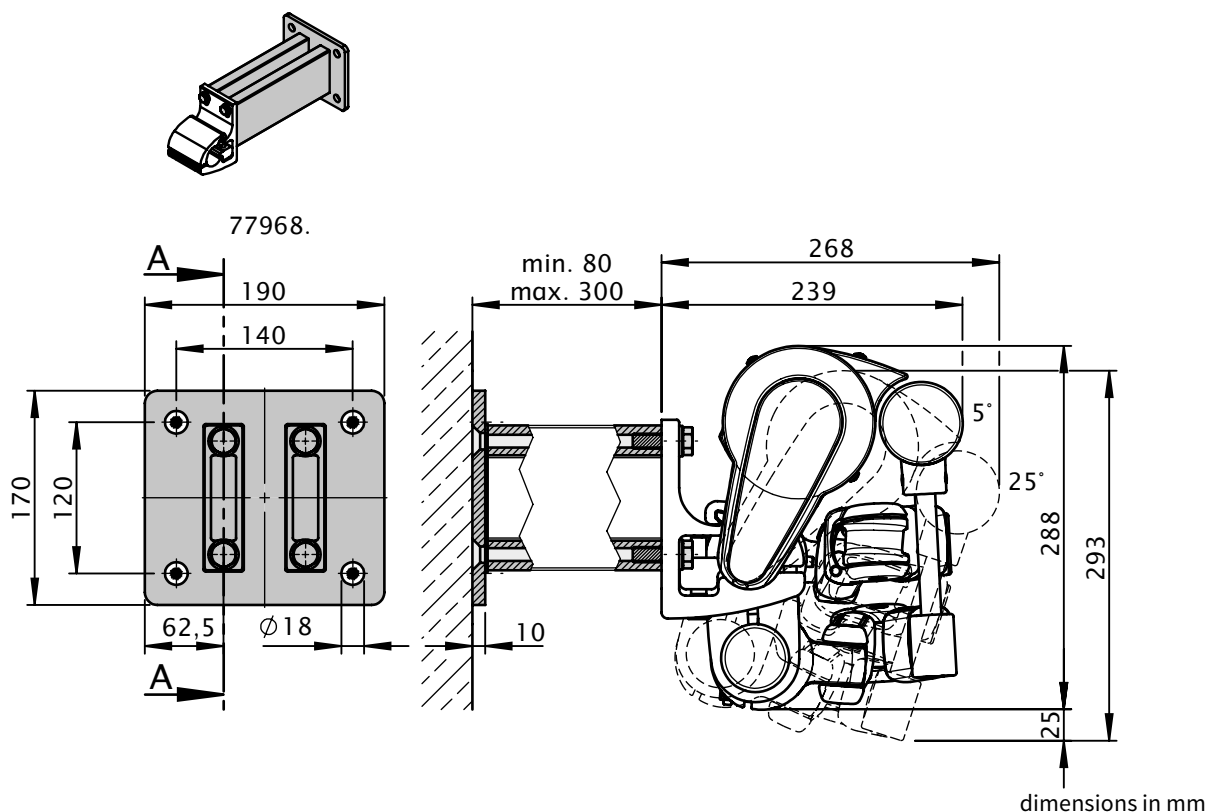

Top fixture

Pull-out force [N=Newton] per upper fixing point according to EN 13561, wind resistance class 2

Compression-proof substrate
M [cm]

	150	175	200	225	250	300	350	400
H [cm]	FB [N]							
150	345	383	-	-	-	-	-	-
200	-	619	675	732	-	-	-	-
250	-	-	944	1024	1104	-	-	-
300	-	-	-	1366	1473	1688	-	-
350	-	-	-	-	1968	2246	2525	-

Non compression-proof substrate
M [cm]

	150	175	200	225	250	300	350	400
H [cm]	FB [N]							
150	472	523	-	-	-	-	-	-
200	-	856	934	1011	-	-	-	-
250	-	-	1313	1423	1533	-	-	-
300	-	-	-	1906	2055	2354	-	-
350	-	-	-	-	2753	3142	3531	-

HT BHT	2 90 mm
----------	-----------

HT BHT	2 90 mm
----------	-----------

BM	8
----	---

BM	8
----	---

The pull-out force refers to the vertical centre to centre measurement between the fixture points of **80 mm**. If the awning is fitted with two brackets per folding arm the pull-out force may be halved.

Place the brackets immediately to the left and right of the arm bearer.

- M = awning width
- H = projection
- FB = pull-out force per fixing point
- HT | BHT = bracket quantity | width
- BM = no. of fixing points
- 70868. = top fixture bracket assembly 90 mm

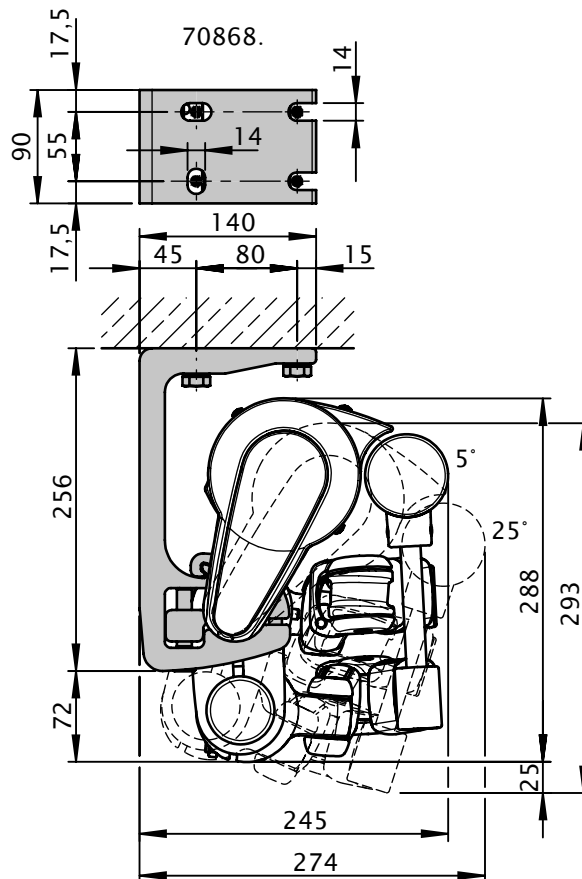

dimensions in mm

Eaves fixture

Torque [Nm = Newton metres] for the fixture bracket next to the arm, shear force [N = Newton] per fixing point according to EN 13561, wind resistance class 2

H [cm]	Torque M [cm]								Shear force M [cm]							
	150	175	200	225	250	300	350	400	150	175	200	225	250	300	350	400
	Md [Nm]								FS [N]							
150	70	77	-	-	-	-	-	-	848	939	-	-	-	-	-	-
200	-	130	141	153	-	-	-	-	-	1532	1671	1810	-	-	-	-
250	-	-	202	219	235	-	-	-	-	-	2345	2543	2740	-	-	-
300	-	-	-	296	319	365	-	-	-	-	-	3401	3667	4201	-	-
350	-	-	-	-	431	491	551	-	-	-	-	-	4909	5603	6296	-
HT	2								2							
BM	8								8							

The shear force is calculated on the basis of 2 fixing points per bracket, because – depending on the roof pitch – it cannot be guaranteed that 4 fixing points per bracket can be used.

- M = awning width
- H = projection
- Md = torque value for the bracket in the immediate vicinity of the arm
- HT = no. of brackets
- FS = shear force
- BM = no. of fixing points

with eaves fixture bracket 150 mm

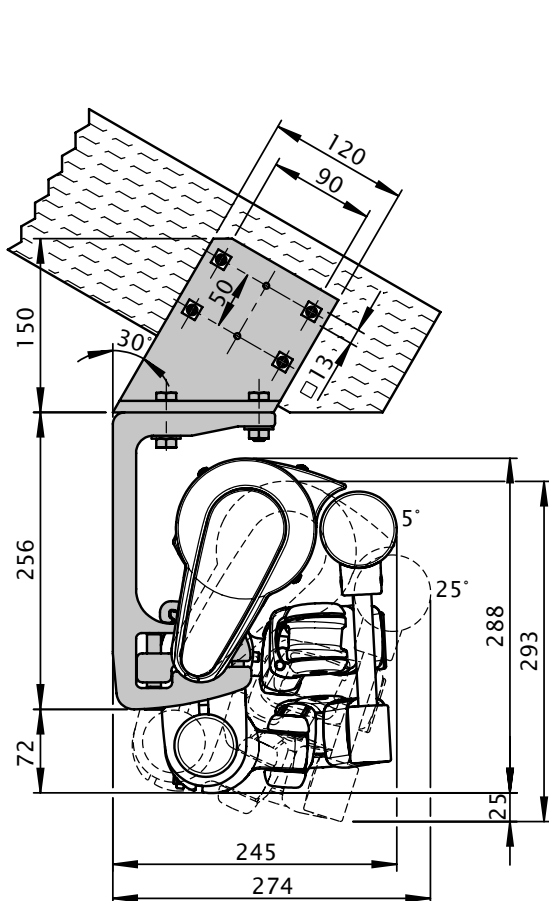

with eaves fixture bracket 270 mm

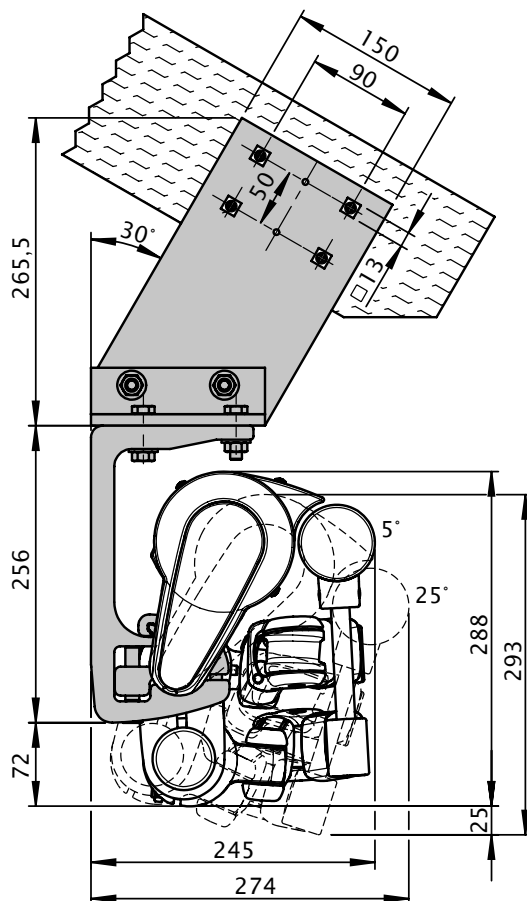

dimensions in mm

01
02
03
04
05
06
07
08
09
10
11
12
13
14
15
16
17
18
19
20
21
22
23

Eaves fixture with additional spreader / backing plate

Torque [Nm = Newton metres] for the fixture bracket in the immediate vicinity of the arm, shear force [N = Newton] per fixing point according to EN 13561, wind resistance class 2

H [cm]	Torque M [cm]								Shear force M [cm]							
	150	175	200	225	250	300	350	400	150	175	200	225	250	300	350	400
	Md [Nm]								FS [N]							
150	70	77	-	-	-	-	-	-	423	471	-	-	-	-	-	-
200	-	130	141	153	-	-	-	-	-	737	807	876	-	-	-	-
250	-	-	202	219	235	-	-	-	-	-	1110	1206	1302	-	-	-
300	-	-	-	296	319	365	-	-	-	-	-	1592	1719	1973	-	-
350	-	-	-	-	431	491	551	-	-	-	-	-	2278	2604	2930	-
HT	2								2							
BM	4								4							

By using the additional flat fixture plate, the shear force is reduced in comparison with conventional eaves fixture.

- M = awning width
- H = projection
- Md = torque value for the bracket in the immediate vicinity of the arm
- HT = no. of brackets
- FS = shear force
- BM = no. of fixing points

with eaves fixture bracket 150 mm

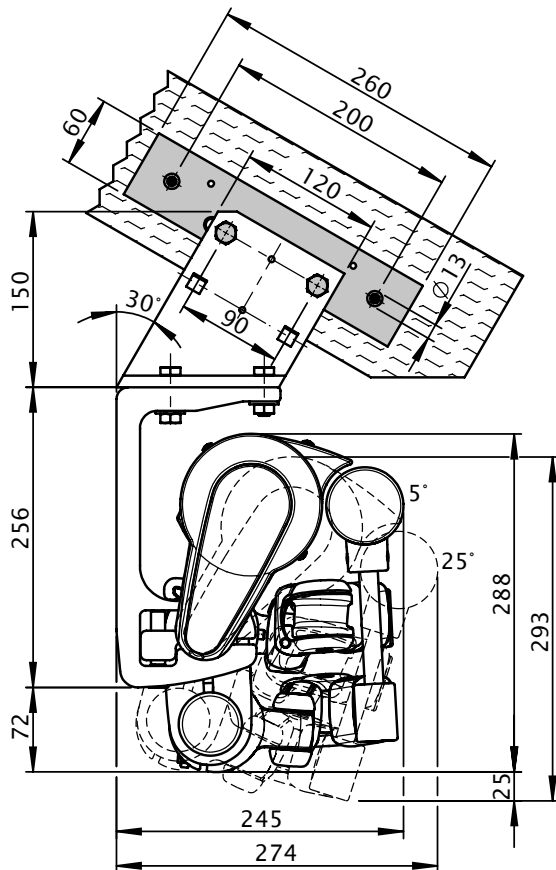

with eaves fixture bracket 270 mm

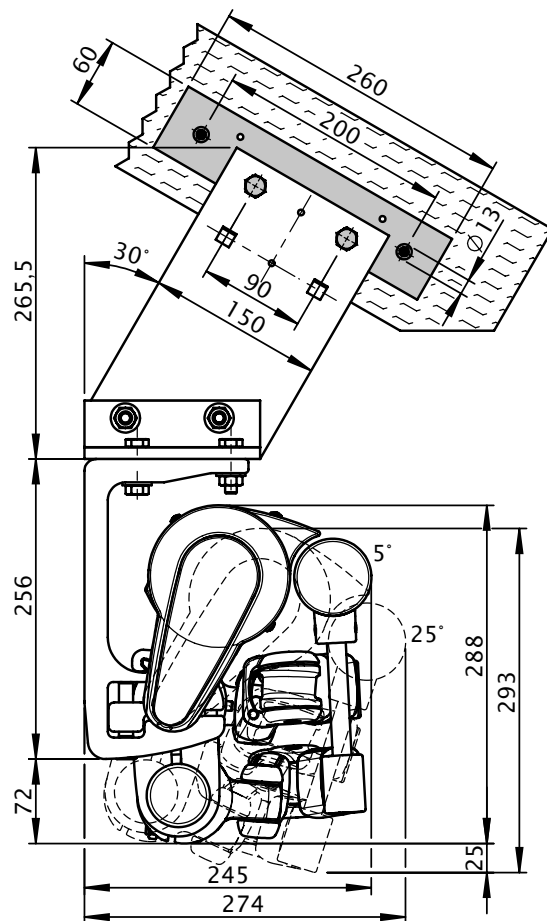

dimensions in mm

Installation using the adjustable eaves fixture bracket

Pull-out force [N=Newton] per upper fixing point according to EN 13561, wind resistance class 2

Compression-proof substrate									Non compression-proof substrate								
M [cm]									M [cm]								
H [cm]									H [cm]								
FB [N]									FB [N]								
150	175	200	225	250	300	350	400		150	175	200	225	250	300	350	400	
150	555	616	-	-	-	-	-	-	150	572	635	-	-	-	-	-	-
200	-	984	1075	1166	-	-	-	-	200	-	1016	1110	1204	-	-	-	-
250	-	-	1493	1621	1748	-	-	-	250	-	-	1543	1675	1806	-	-	-
300	-	-	-	2153	2324	2664	-	-	300	-	-	-	2226	2402	2754	-	-
350	-	-	-	-	3094	3534	3974	-	350	-	-	-	-	3200	3655	4110	-
HT BHT									HT BHT								
2 90 mm									2 90 mm								
BM									BM								
8									8								

The pull-out force refers to the measurement from the front to the rear fixture points of 140 mm.

Washers conforming to DIN 9021 must be used.

- M = awning width
- H = projection
- FB = pull-out force per fixing point
- HT | BHT = bracket quantity | width
- BM = no. of fixing points

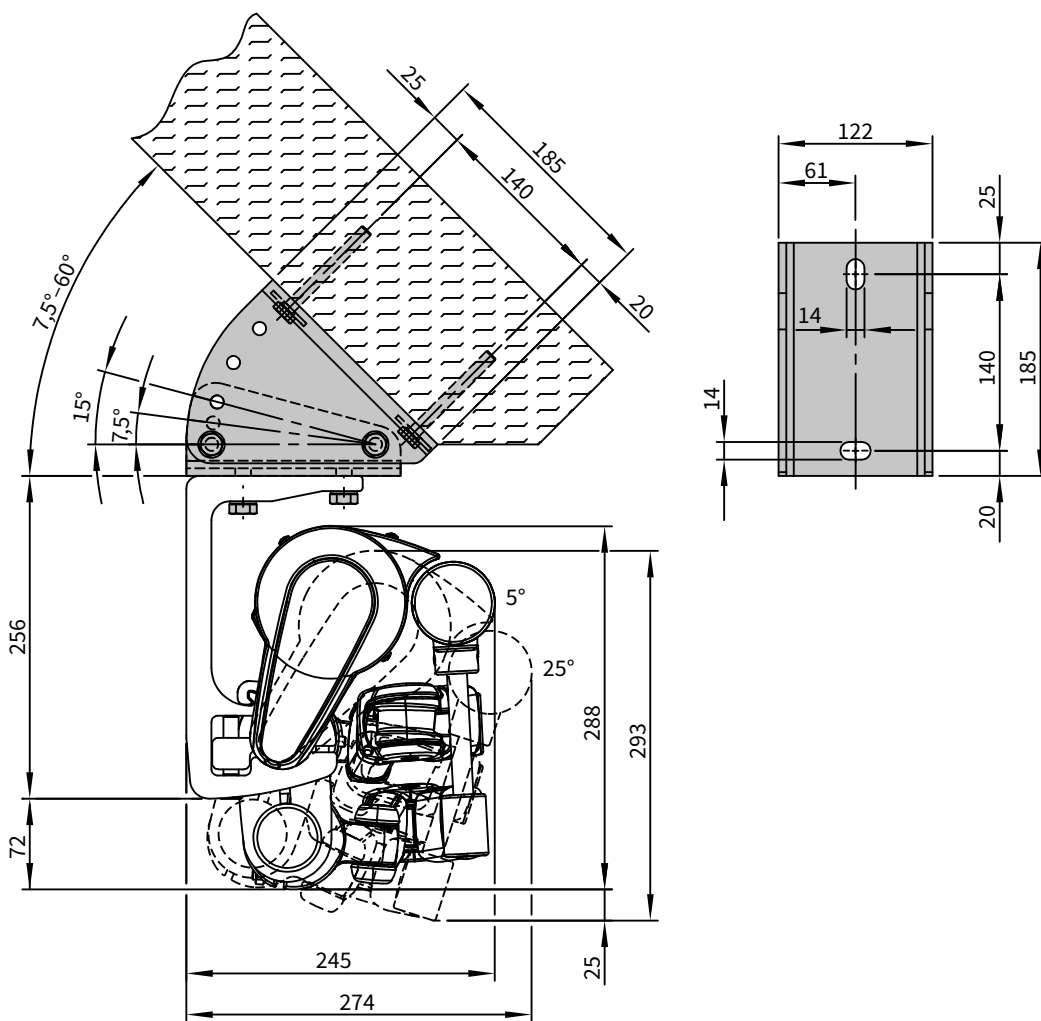

dimensions in mm

- 01
- 02
- 03
- 04
- 05
- 06
- 07
- 08
- 09
- 10
- 11
- 12
- 13
- 14
- 15
- 16
- 17
- 18
- 19
- 20
- 21
- 22
- 23

Face fixture with manual operation

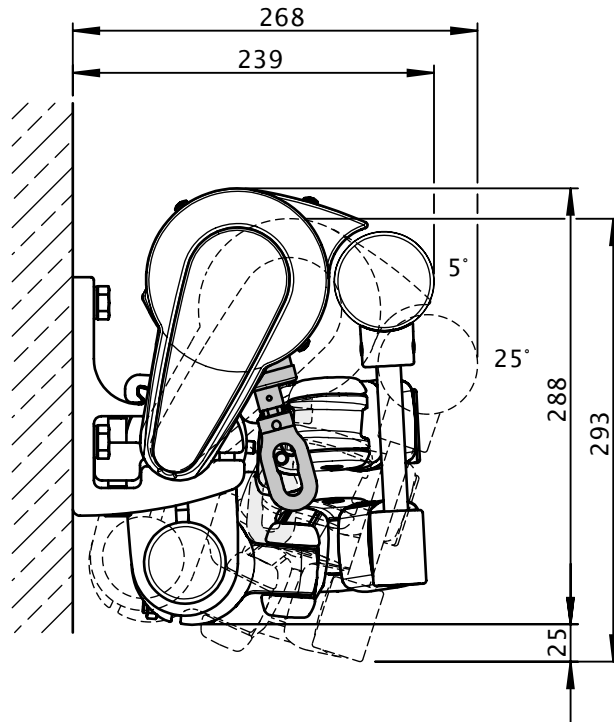

dimensions in mm

Face fixture with wall sealing profile

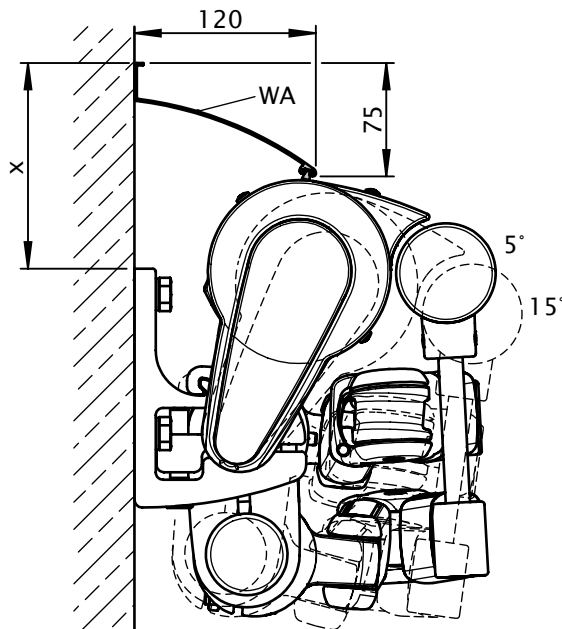

awning pitch	X
5°	136 mm
10°	132 mm
15°	127 mm
20°	—
25°	—

WA = wall sealing profile

X = distance upper edge face fixture bracket to upper edge wall sealing profile

dimensions in mm

Cable exit position in motor-driven units

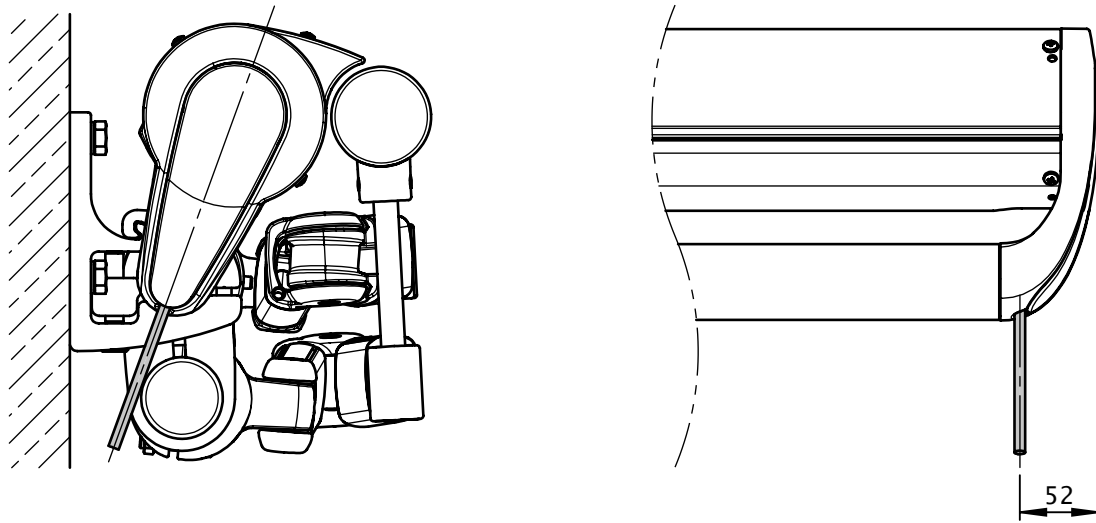

01
02
03
04
05
06
07
08
09
10
11
12
13
14
15
16
17
18
19
20
21
22
23

dimensions in mm

Bracket fixture range for awnings with 2 folding arms

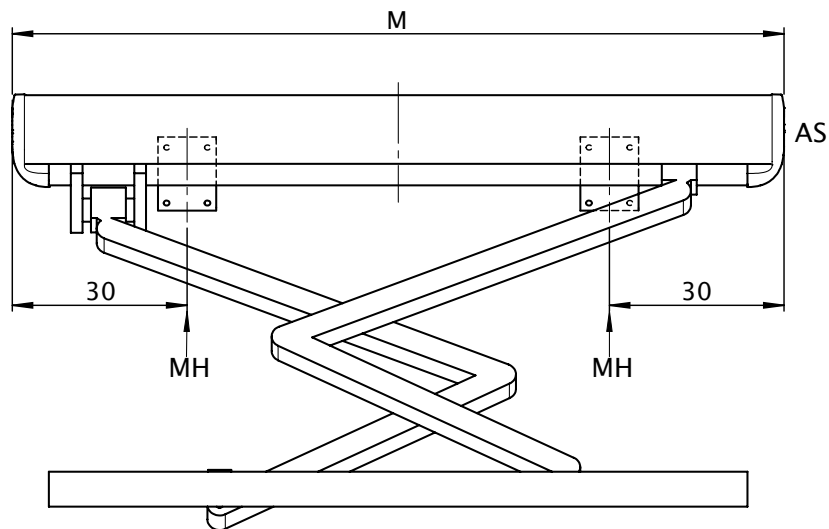

dimensions in cm

If the brackets cannot be positioned in accordance with this table, make sure the actual measurements are noted on the order form!

- AS = drive side
- M = awning width
- MH = bracket centre

