



markilux 1500

**The semi-cassette awning with gas piston arm technology
Something special – and not just technically speaking**





side view with awning retracted, face fixture



side view with awning retracted, top fixture



the gas piston-tensioned arms ensure reliable and simple operation

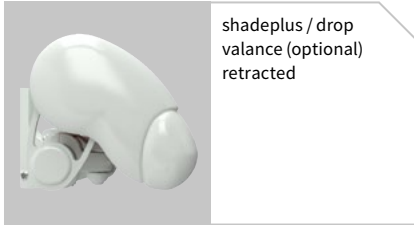

shadeplus / drop valance (optional) retracted

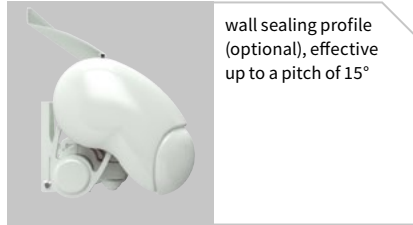

wall sealing profile (optional), effective up to a pitch of 15°



pitch adjustment via the fixture brackets



side view with winding handle, manual operation

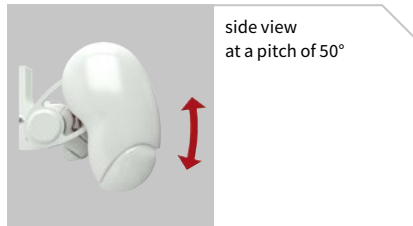

side view at a pitch of 50°

Design Features

presented with the IF Design Award for excellent design

folding-arm awning in a semi-cassette version; the dynamically rounded coverboard gives the awning the appearance of being fully cassetted

elegant and robust front profile made of aluminium

Technical Specification

attractive ovoid folding arms with unique gas piston technology ensure a taut cover in every extended position

sturdy, round steel torque bar, 50 mm Ø, to prevent twist and deflection

folding arms with drop-forged joint components and Teflon-coated bronze bushes, which provide superior robustness and durability

coverboard with integrated brush, so that larger pieces of dirt and debris cannot be drawn into the awning

awning covers made of sunsilk snc or sunvas snc with self-cleaning effect

Optional Accessories

the shadeplus creates an additional room on the patio. Protection from the sun, the wind and inquisitive glances all in one

radio-controlled motor with radio remote control for ease of use

hard-wired motor operation (optionally with automatic weather controls) for straightforward and easy operation

wall sealing profile to cover the gap between awning and wall

awning available in non-standard RAL colours

available with a valance

Lounge colours

markilux 1500

off-white textured finish 5233

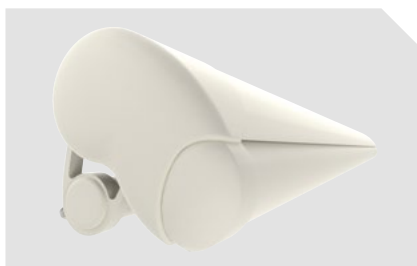

Designer end caps in polished chrome

off-white textured finish 5233



stone grey metallic 5215



stone grey metallic 5215



Havana brown textured finish 5229



Havana brown textured finish 5229

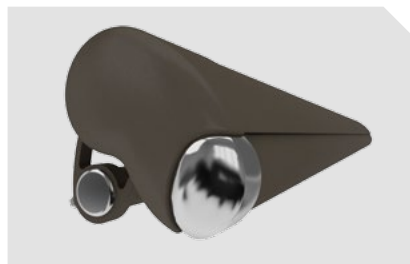

anthracite metallic 5204





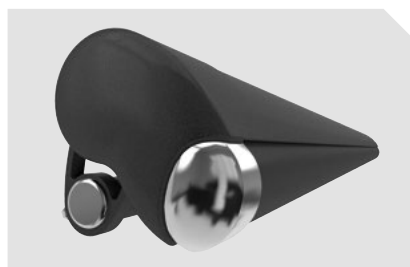

anthracite metallic 5204

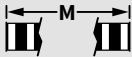
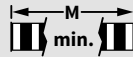

- 01
- 02
- 03
- 04
- 05
- 06
- 07
- 08
- 09
- 10
- 11
- 12
- 13
- 14
- 15
- 16
- 17
- 18
- 19
- 20
- 21
- 22
- 23

Colours may differ slightly from those depicted in both hue and finish.

Dimensions and configuration options

												
		260	310	360	410	460	510	560	610	660		
		193 260	261 310	311 360	361 410	411 460	461 510	511 560	561 610	611 660		
	150										193	196
	200	1)									243	246
	250	—	1)								293	296
	300	—	—	1)							343	346
	350	—	—	—	1)					—	393	396

dimensions in cm

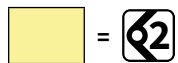

1) note the minimum widths!

Operation / Drive

	standard	optional
manual operation	<input checked="" type="checkbox"/>	—
servo-assisted operation	—	<input checked="" type="checkbox"/>
hard-wired motor	—	<input checked="" type="checkbox"/>
io radio controls	—	<input checked="" type="checkbox"/>
radio-controlled motor (433 MHz)	—	<input checked="" type="checkbox"/>

Miscellaneous

	standard	optional
shadeplus / drop valance manual operation	—	<input checked="" type="checkbox"/>
wall sealing profile	—	<input checked="" type="checkbox"/> ²⁾
light and wind sensor	—	<input checked="" type="checkbox"/>
insertable side blind	—	<input checked="" type="checkbox"/>
valance	—	<input checked="" type="checkbox"/>
infrared heater	—	<input checked="" type="checkbox"/>
vibrabox / radio control light sensor Sunis WireFree	—	<input checked="" type="checkbox"/>

2) up to a maximum awning pitch of 15°

Covers





	fabric range no.	standard	optional
sunsilk snc	324 .. / 328 .. / 369 ..	<input checked="" type="checkbox"/>	—
sunsilk perla FR	374 ..	—	<input checked="" type="checkbox"/>
sunvas	310 .. / 311 .. 313 .. — 315 ..	<input checked="" type="checkbox"/>	—
sunvas perla	370 ..	—	<input checked="" type="checkbox"/>

Coupled units









	standard	optional
2 fields	—	<input checked="" type="checkbox"/> ³⁾
junction roller	—	<input checked="" type="checkbox"/> ⁴⁾

3) for minimum widths please consult the section “Technical Information”

4) see overview “Bracket fixture range”

 = motor	 = manual operation	M = awning width
 = no. of folding arms	 = no. of rolltex bearings	M min. = minimum widths
		H = projection

Frame colours

		standard	optional
traffic white	RAL 9016		
metallic aluminium	RAL 9006		
grey brown, similar to	RAL 8019		
light ivory	RAL 1015		
anthracite metallic	5204		
stone grey metallic	5215		
off-white textured finish	5233		
Havana brown textured finish	5229		
non-standard powder-coated finish			

Other end cap colour options

	standard	optional
polished chrome		

Dimensions and tolerances

	width	projection
housing tolerances	+ 5 / - 15 mm	± 40 mm
awning cover width = awning width	- 260 mm	
awning cover length = awning projection		+ 180 mm

Additional information

The width of the awning cover is always **less** than that of the awning.

Pitch adjustment range: from 5° to 50° (to the horizontal).

Definition of projection: Please consult the section “Technical Information”.

In the case of manual operation approximately **16 winding handle revolutions can be assumed per metre of awning projection.**

It takes approximately **12 seconds per metre** to extend the awning in the case of **motor-driven units.**

Definition of shadeplus drop: The shadeplus drop is measured from the bottom edge of the shadeplus profile to the bottom edge of the valance profile. Due to fabric thickness tolerances the actual drop may be shorter than the nominal drop by up to 5 cm. For the maximum shadeplus drops please consult the section “Technical Information”.

A shadeplus is not available with sunsilk perla FR, sunvas perla or PVC covers.

Coupled folding-arm awnings are available up to a **max. of 2 single units** side by side, however **only with a motor.**

A coupled unit is available with **junction roller.** Pattern repeat mismatches are possible in the case of junction roller covers. A junction roller may not fit when the projection is the maximum for the width of each awning. (see also the section on “Installation”, the arm separation table).

If coupled awnings are fitted into a **recess or reveal** the overall width of the coupled awning must be at least 6 cm less than the width of the opening to allow the awning to be coupled.

Colours similar to those in the RAL chart. Colours may differ slightly from those depicted in both hue and finish.

01
02
03
04
05
06
07
08
09
10
11
12
13
14
15
16
17
18
19
20
21
22
23

Fixtures, fittings and accessories

Fixture brackets

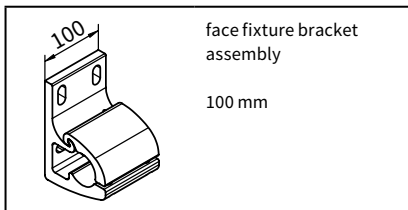

face fixture bracket assembly
100 mm

70867.

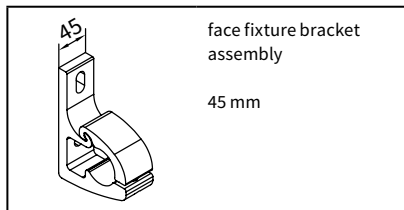

face fixture bracket assembly
45 mm

71813.

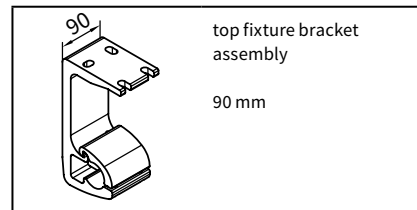

top fixture bracket assembly
90 mm

70868.

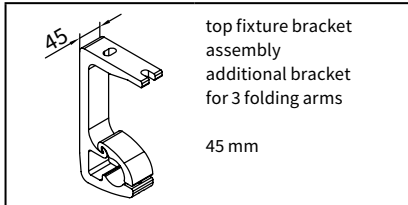

top fixture bracket assembly
additional bracket for 3 folding arms
45 mm

71818.

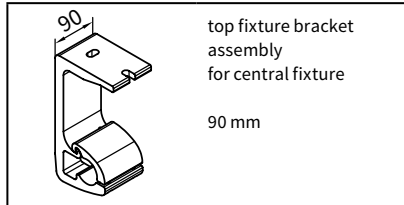

top fixture bracket assembly for central fixture
90 mm

70869.

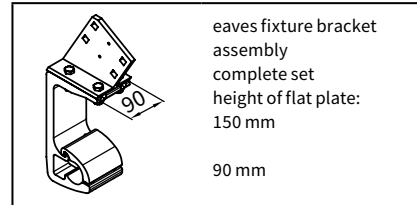

eaves fixture bracket assembly complete set
height of flat plate: 150 mm
90 mm

70871.

Spreader and spacer plates

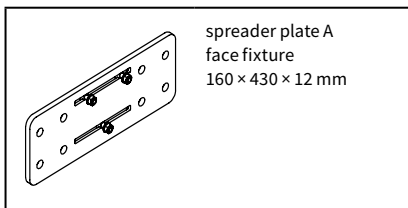

spreader plate A face fixture
160 x 430 x 12 mm

75326.

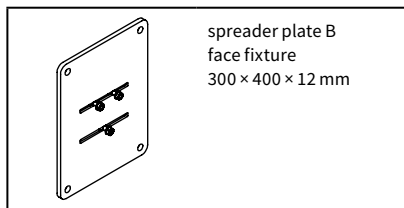

spreader plate B face fixture
300 x 400 x 12 mm

75325.

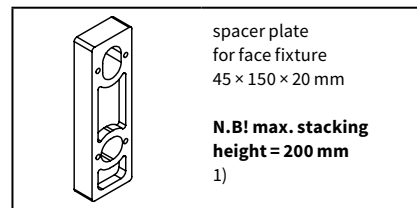

spacer plate for face fixture
45 x 150 x 20 mm

N.B! max. stacking height = 200 mm
1)

718251

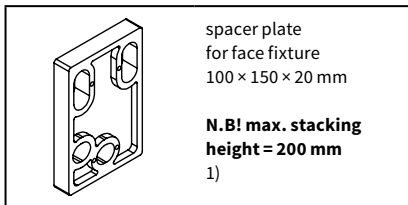

spacer plate for face fixture
100 x 150 x 20 mm
N.B! max. stacking height = 200 mm
1)

718231

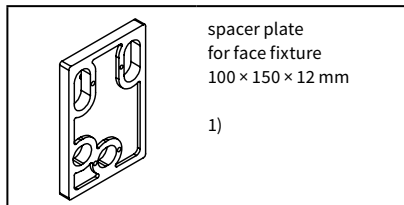

spacer plate for face fixture
100 x 150 x 12 mm
1)

718241

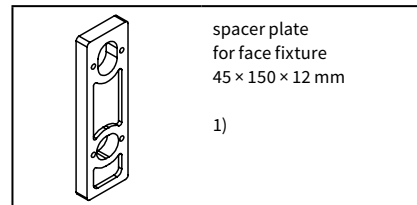

spacer plate for face fixture
45 x 150 x 12 mm
1)

71826.

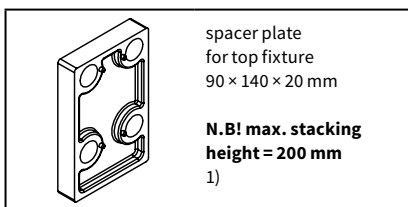

spacer plate for top fixture
90 x 140 x 20 mm
N.B! max. stacking height = 200 mm
1)

716311

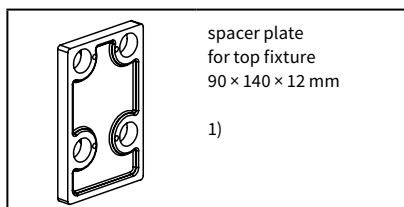

spacer plate for top fixture
90 x 140 x 12 mm
1)

716411

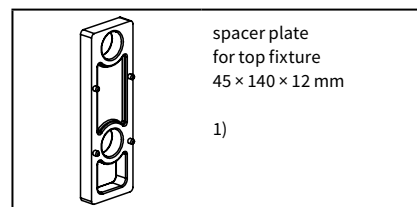

spacer plate for top fixture
45 x 140 x 12 mm
1)

716371

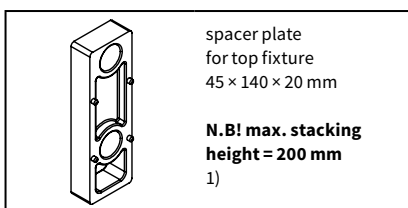

spacer plate for top fixture
45 x 140 x 20 mm
N.B! max. stacking height = 200 mm
1)

716261

1) please refer to the section "Technical Information"

. = insert RAL colour code no

Stand-off brackets

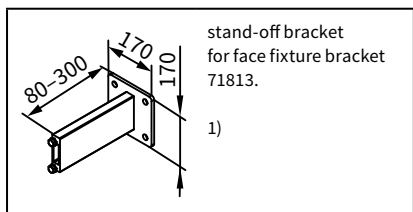

77967.

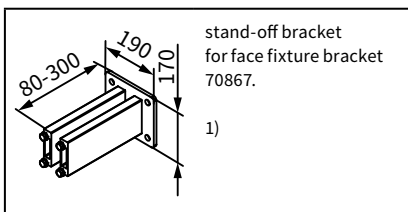

77968.

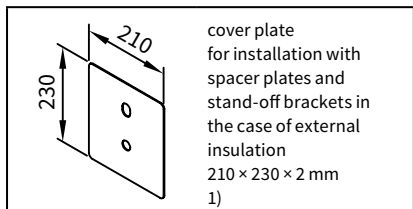

71844.

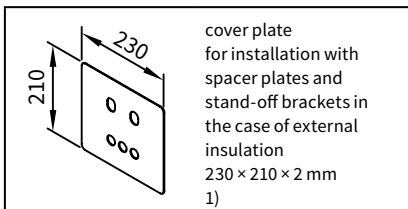

71843.

Accessories

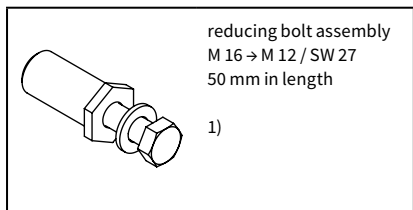

753891

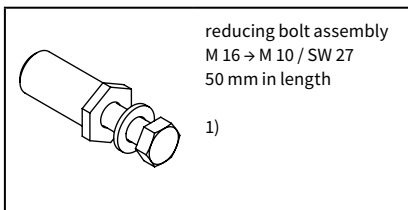

754921

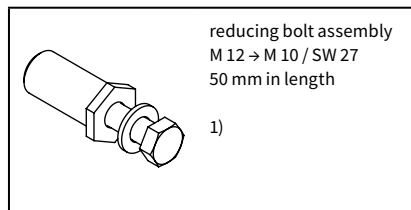

754911

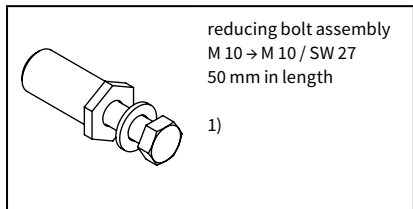

754901

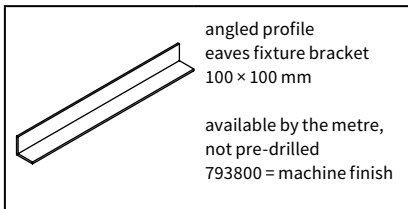

79380.

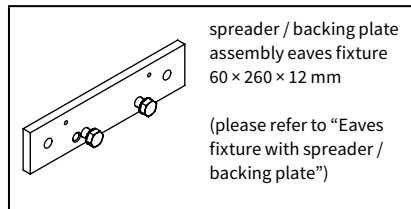

75383.

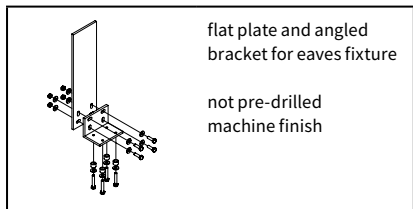

716620

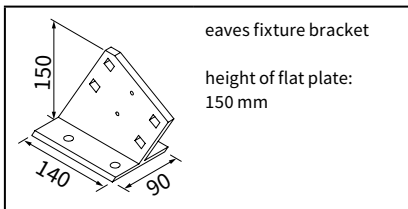

71612.

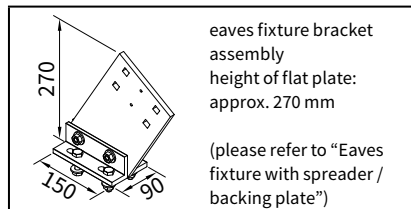

71659.

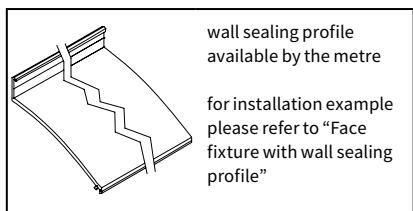

77780.

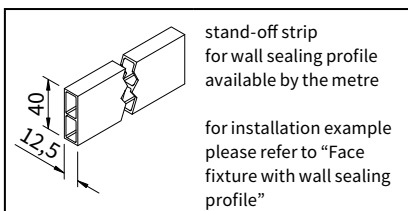

751971

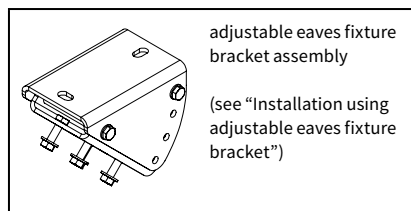

71198.

1) please refer to the section "Technical Information"

. = insert RAL colour code no

Face fixture with spreader plate A

Pull-out force [N=Newton] per upper fixing point according to EN 13561, wind resistance class 2

Compression-proof substrate

H [cm]	M [cm]								
	260	310	360	410	460	510	560	610	660
150	272	308	345	381	418	455	491	528	565
200	426	484	541	599	657	715	772	830	888
250	-	693	776	859	943	1026	1110	1193	1438
300	-	-	1054	1168	1282	1395	1704	1836	1968
350	-	-	-	1518	1883	2056	2229	2402	-

Non compression-proof substrate

H [cm]	M [cm]								
	260	310	360	410	460	510	560	610	660
150	386	438	490	542	594	646	698	750	802
200	605	687	769	851	933	1016	1098	1180	1262
250	-	984	1103	1221	1340	1458	1577	1696	2044
300	-	-	1498	1660	1821	1983	2422	2610	2797
350	-	-	-	2157	2676	2922	3167	3413	-

HT BHT	2 100 mm	2 100 mm 1 45 mm
----------	------------	-------------------------

HT BHT	2 100 mm	2 100 mm 1 45 mm
----------	------------	-------------------------

BP	2	2
DP	-	1
BM	16	18

BP	2	2
DP	-	1
BM	16	18

The pull-out force refers to the vertical centre to centre measurement between the fixture points of **76 mm**.

In the case of spreader plates washers conforming to DIN 9021 must be used.

- M = awning width
- H = projection
- FB = pull-out force per fixing point
- HT | BHT = bracket quantity | width
- BP = no. of spreader plates
- DP = no. of spacer plates
- BM = no. of fixing points
- WA = wall sealing profile
- 75197. = stand-off strip for wall sealing profile

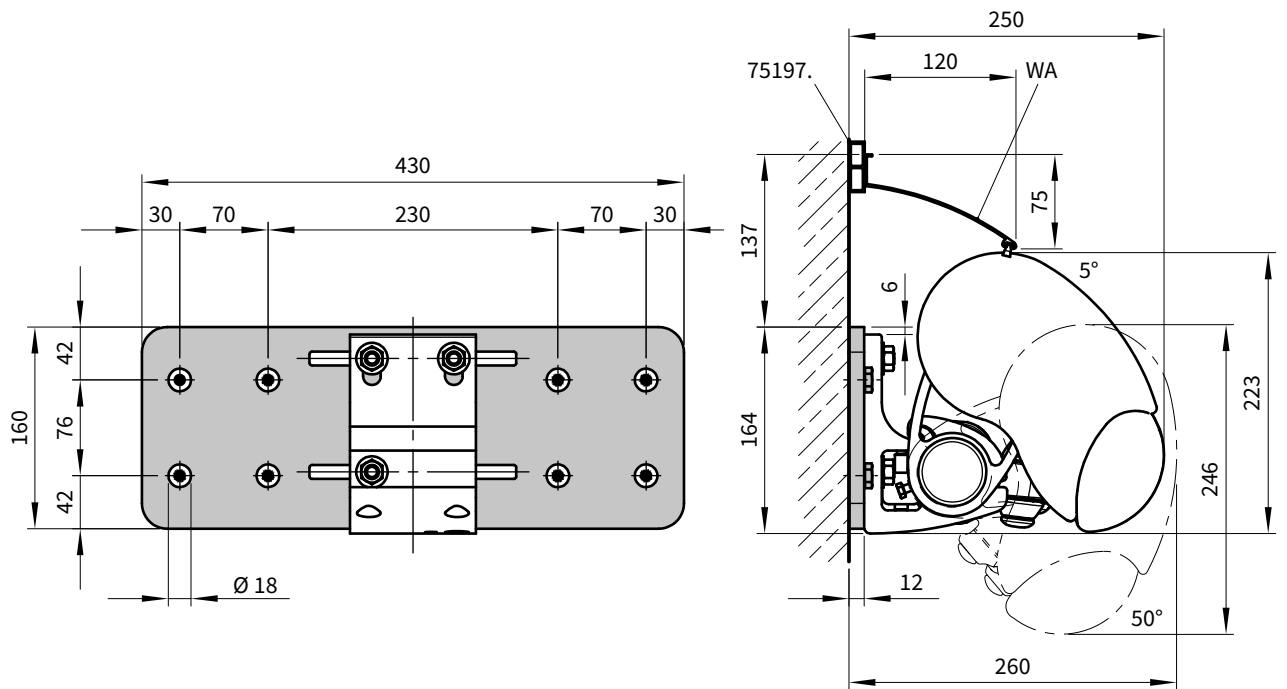

dimensions in mm

Face fixture with spreader plate B

Pull-out force [N=Newton] per upper fixing point according to EN 13561, wind resistance class 2

Compression-proof substrate

M [cm]

260	310	360	410	460	510	560	610	660
-----	-----	-----	-----	-----	-----	-----	-----	-----

H [cm]

FB [N]

150	161	182	204	226	247	269	291	312	334
200	252	286	320	355	389	423	457	491	525
250	-	410	459	509	558	607	657	706	851
300	-	-	624	691	758	826	1009	1087	1165
350	-	-	-	898	1114	1217	1319	1412	-

Non compression-proof substrate

M [cm]

260	310	360	410	460	510	560	610	660
-----	-----	-----	-----	-----	-----	-----	-----	-----

FB [N]

168	190	213	235	258	281	303	326	348
263	298	334	370	405	441	477	512	548
-	427	479	530	582	633	685	736	888
-	-	651	721	791	861	1052	1133	1215
-	-	-	937	1162	1269	1376	1482	-

HT BHT	2 100 mm	2 100 mm 1 45 mm
----------	------------	-------------------------

HT BHT	2 100 mm	2 100 mm 1 45 mm
----------	------------	-------------------------

BP	2	2
DP	-	1
BM	8	10

BP	2	2
DP	-	1
BM	8	10

The pull-out force refers to the vertical centre to centre measurement between the fixture points of **350 mm**.

In the case of spreader plates washers conforming to DIN 9021 must be used.

- M = awning width
- H = projection
- FB = pull-out force per fixing point
- HT | BHT = bracket quantity | width
- BP = no. of spreader plates
- DP = no. of spacer plates
- BM = no. of fixing points

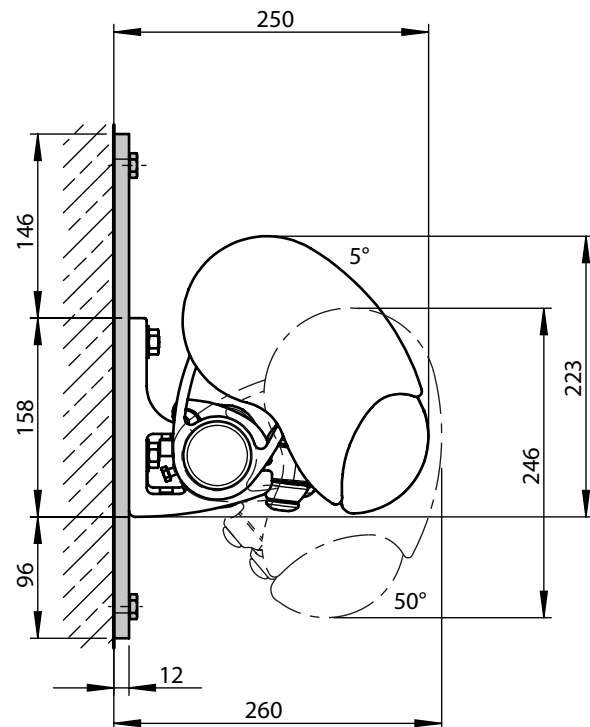
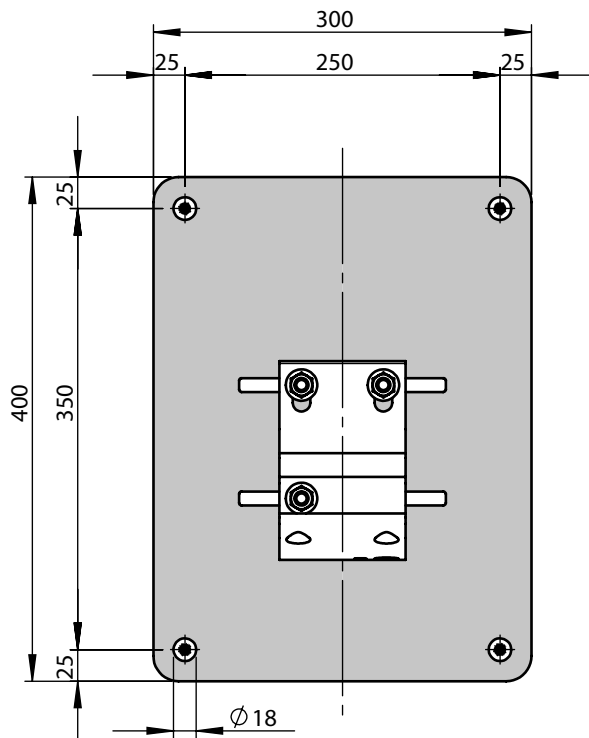

dimensions in mm

Face fixture with stand-off brackets

Pull-out force [N=Newton] per upper fixing point according to EN 13561, wind resistance class 2

Compression-proof substrate										Non compression-proof substrate										
M [cm]										M [cm]										
H [cm]										FB [N]										
260	310	360	410	460	510	560	610	660		260	310	360	410	460	510	560	610	660		
150	565	640	715	789	864	939	1014	1089	1164	635	720	804	888	972	1056	1141	1225	1309		
200	841	954	1067	1180	1293	1405	1518	1631	1744	946	1073	1200	1327	1454	1581	1708	1835	1962		
250	-	1321	1479	1637	1795	1953	2111	2269	2742	-	1487	1664	1842	2020	2198	2375	2553	3085		
300	-	-	1963	2173	2384	2594	3175	3420	3665	-	-	2208	2445	2682	2918	3572	3847	4123		
350	-	-	-	2775	3445	3761	4077	4393	-	-	-	-	3121	3876	4232	4587	4943	-		
HT BHT	2 100 mm				2 100 mm 1 45 mm						2 100 mm				2 100 mm 1 45 mm					
DH 77968.	2				2						2				2					
DH 77967.	-				1						-				1					
BM	8				12						8				12					

The pull-out force refers to the vertical centre to centre measurement between the fixture points of **120 mm**.
In the case of stand-off brackets washers conforming to DIN 9021 must be used.

- M = awning width
- H = projection
- FB = pull-out force per fixing point
- HT | BHT = bracket quantity | width
- BM = no. of fixing points
- DH = no. of stand-off brackets
- 77967. = stand-off bracket for face fixture bracket assembly 70813.
- 77968. = stand-off bracket for face fixture bracket assembly 70867.

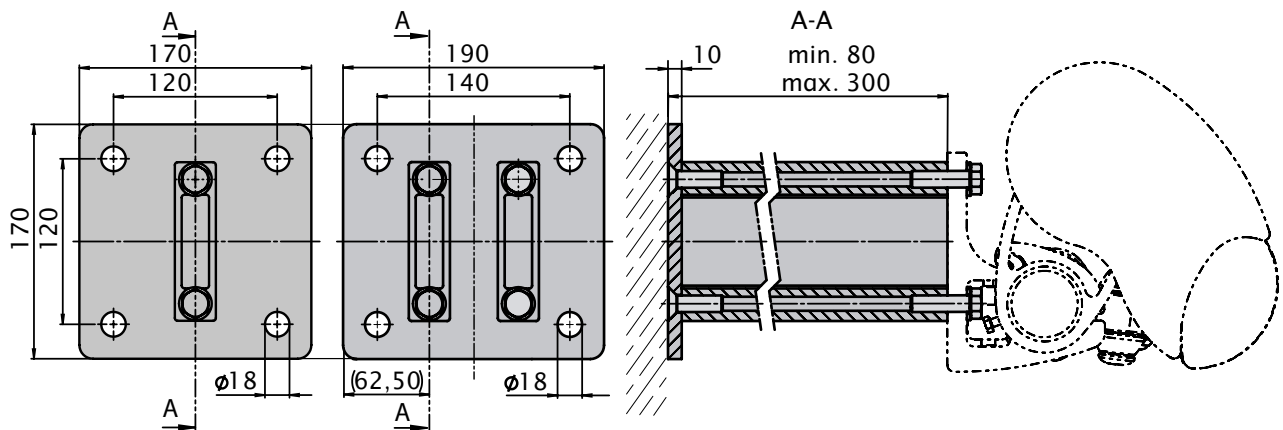
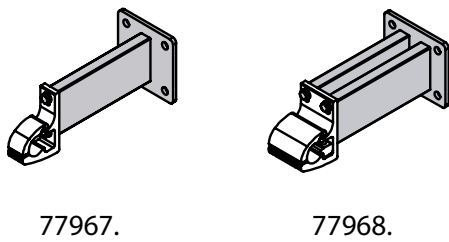

dimensions in mm

Face fixture with shadeplus

Pull-out force [N=Newton] per upper fixing point according to EN 13561, wind resistance class 2

Compression-proof substrate

Non compression-proof substrate

		M [cm]									M [cm]								
		260	310	360	410	460	510	560	610	660	260	310	360	410	460	510	560	610	660
H [cm]	FB [N]										FB [N]								
150		549	627	706	784	863	941	1020	1098	1177	750	857	965	1072	1179	1287	1394	1501	1608
200		844	965	1085	1206	1326	1446	1567	1687	1808	1154	1318	1483	1648	1812	1977	2141	2306	2471
250		-	1361	1531	1702	1872	2042	2213	2383	2834	-	1860	2093	2326	2558	2791	3024	3257	3874
300		-	-	2048	2276	2504	2732	3301	3561	3821	-	-	2799	3111	3422	3734	4512	4867	5223
350		-	-	-	2936	3608	3945	4282	4619	-	-	-	-	4013	4930	5391	5852	6312	-

HT BHT	2 100 mm	2 100 mm 1 45 mm	2 100 mm 1 45 mm
----------	------------	-------------------------	-------------------------

BM	6	8	6	8
----	---	---	---	---

The pull-out force refers to the vertical centre to centre measurement between the fixture points of **90 mm**. If this measurement is reduced to the minimum, the pull-out force increases by **14%** in the case of **compression-proof substrates** and by **19%** in the case of **non compression-proof substrates**.

If the awning is fixed with 2 brackets per folding arm, the pull-out force can be halved.

Place the brackets immediately to the left and right of the arm bearer.

- M = awning width
- H = projection
- FB = pull-out force per fixing point
- HT | BHT = bracket quantity | width
- BM = no. of fixing points
- WA = wall sealing profile
- 71813. = face fixture bracket assembly 45 mm
- 70867. = face fixture bracket assembly 100 mm

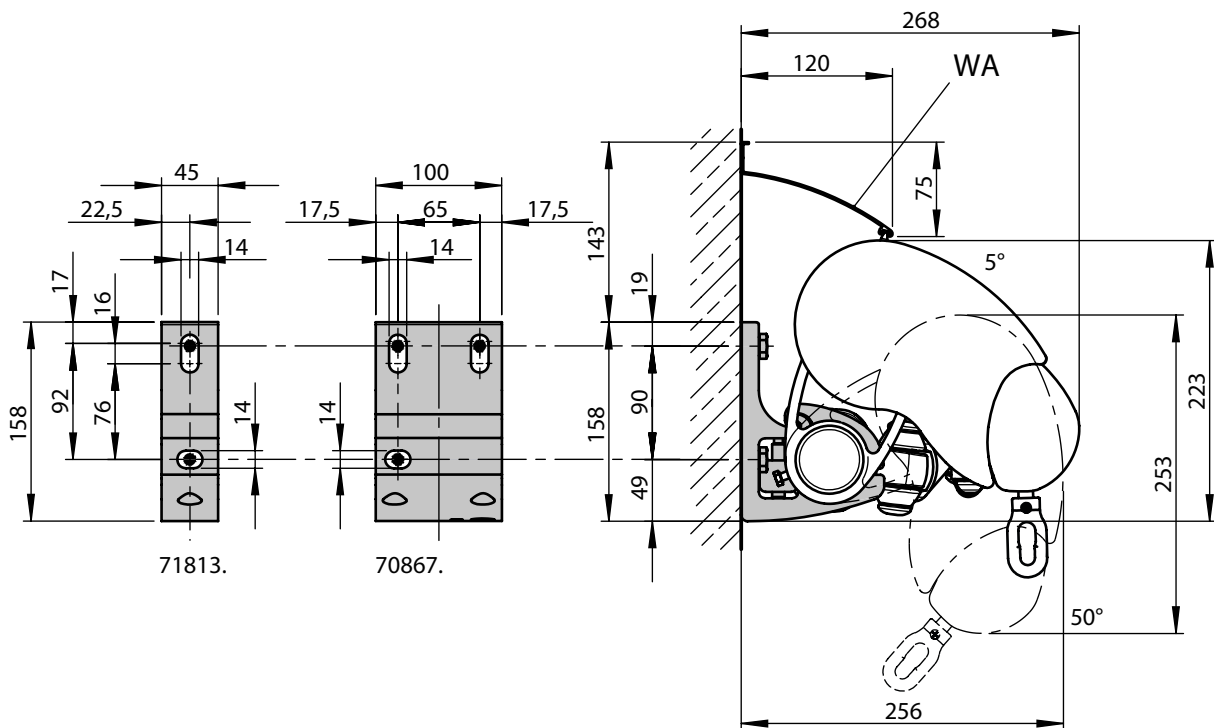

dimensions in mm

Face fixture with shadeplus and spreader plate B

Pull-out force [N=Newton] per upper fixing point according to EN 13561, wind resistance class 2

Compression-proof substrate

H [cm]	M [cm]								
	260	310	360	410	460	510	560	610	660
150	187	214	241	267	294	321	348	374	401
200	287	328	369	410	451	492	533	574	615
250	-	462	520	578	636	693	751	809	962
300	-	-	697	774	852	929	1122	1210	1298
350	-	-	-	995	1223	1337	1451	1565	-

Non compression-proof substrate

H [cm]	M [cm]								
	260	310	360	410	460	510	560	610	660
150	195	223	251	279	307	335	363	390	418
200	299	342	385	428	470	513	556	598	641
250	-	482	542	603	663	723	783	844	1004
300	-	-	727	807	888	969	1170	1262	1354
350	-	-	-	1038	1275	1394	1513	1633	-

HT BHT	2 100 mm	2 100 mm 1 45 mm
BP	2	2
DP	-	1
BM	8	10

HT BHT	2 100 mm	2 100 mm 1 45 mm
BP	2	2
DP	-	1
BM	8	10

HT BHT	2 100 mm	2 100 mm 1 45 mm
BP	2	2
DP	-	1
BM	8	10

HT BHT	2 100 mm	2 100 mm 1 45 mm
BP	2	2
DP	-	1
BM	8	10

The pull-out force refers to the vertical centre to centre measurement between the fixture points of **350 mm**.

In the case of spreader plates washers conforming to DIN 9021 must be used.

- M = awning width
- H = projection
- FB = pull-out force per fixing point
- HT | BHT = bracket quantity | width
- BP = no. of spreader plates
- DP = no. of spacer plates
- BM = no. of fixing points

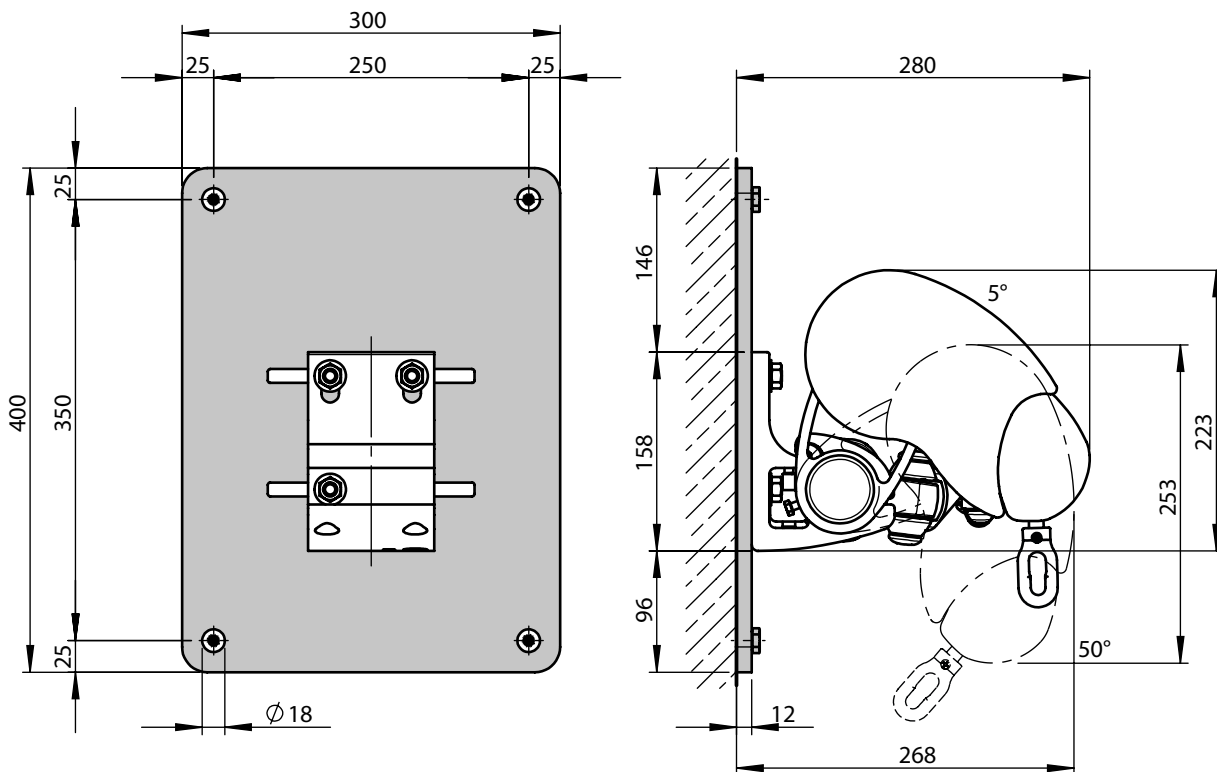

dimensions in mm

Face fixture for shadeplus / drop valance with stand-off brackets

Pull-out force [N=Newton] per upper fixing point according to EN 13561, wind resistance class 2

		Compression-proof substrate								Non compression-proof substrate									
		M [cm]								M [cm]									
		260	310	360	410	460	510	560	610	660	260	310	360	410	460	510	560	610	660
H [cm]	FB [N]																		
150		650	741	832	923	1015	1106	1197	1288	1379	731	834	936	1039	1141	1244	1347	1449	1552
200		950	1084	1217	1351	1485	1619	1752	1886	2020	1069	1219	1369	1520	1670	1821	1971	2122	2272
250		-	1479	1663	1846	2029	2213	2396	2580	3078	-	1664	1870	2077	2283	2489	2696	2902	3463
300		-	-	2179	2419	2659	2900	3511	3786	4061	-	-	2451	2721	2992	3262	3949	4259	4568
350		-	-	-	3058	3763	4113	4464	4815	-	-	-	-	3440	4233	4628	5022	5416	-

HT BHT	Compression-proof substrate	Non compression-proof substrate
	2 100 mm	2 100 mm 1 45 mm

	Compression-proof substrate	Non compression-proof substrate
DH 77968.	2	2
DH 77967.	-	1
BM	8	12

The pull-out force refers to the vertical centre to centre measurement between the fixture points of 120 mm. In the case of stand-off brackets washers conforming to DIN 9021 must be used.

- M = awning width
- H = projection
- FB = pull-out force per fixing point
- HT | BHT = bracket quantity | width
- BM = no. of fixing points
- DH = no. of stand-off brackets
- 71813. = stand-off bracket for face fixture bracket 71813.
- 70867. = stand-off bracket for face fixture bracket 70867.

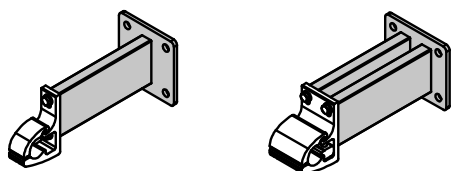

77967. 77968.

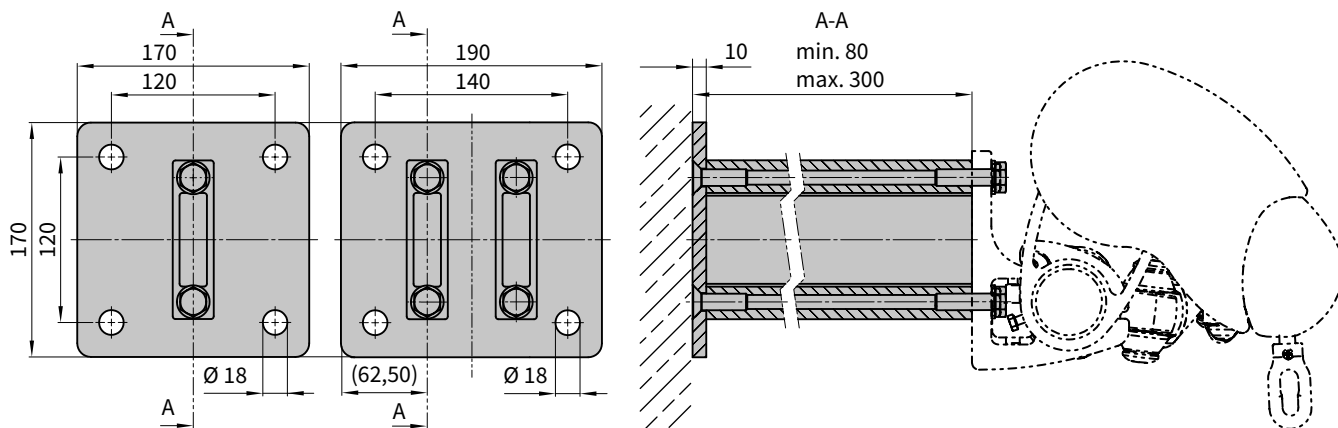

dimensions in mm

01
02
03
04
05
06
07
08
09
10
11
12
13
14
15
16
17
18
19
20
21
22
23

Top fixture

Pull-out force [N=Newton] per upper fixing point according to EN 13561, wind resistance class 2

Compression-proof substrate

M [cm]

260	310	360	410	460	510	560	610	660
-----	-----	-----	-----	-----	-----	-----	-----	-----

Non compression-proof substrate

M [cm]

260	310	360	410	460	510	560	610	660
-----	-----	-----	-----	-----	-----	-----	-----	-----

H [cm]	FB [N]								
150	617	704	791	878	965	1052	1138	1225	1312
200	932	1063	1193	1323	1453	1584	1714	1844	1974
250	-	1491	1674	1857	2039	2222	2405	2588	3100
300	-	-	2237	2482	2726	2971	3615	3897	4179
350	-	-	-	3207	3965	4331	4698	5064	-

H [cm]	FB [N]								
150	789	900	1010	1120	1230	1340	1451	1561	1671
200	1203	1371	1538	1705	1872	2039	2206	2373	2540
250	-	1933	2169	2405	2641	2877	3113	3349	4017
300	-	-	2908	3225	3542	3859	4701	5067	5433
350	-	-	-	4177	5168	5645	6122	6599	-

HT BHT	2 90 mm	2 90 mm 1 45 mm
----------	-----------	------------------------

HT BHT	2 90 mm	2 90 mm 1 45 mm
----------	-----------	------------------------

BM	8	10
----	---	----

BM	8	10
----	---	----

The pull-out force refers to the vertical centre to centre measurement between the fixture points of **80 mm**. If the awning is fitted with two brackets per folding arm the pull-out force may be halved.

Place the brackets immediately to the left and right of the arm bearer.

- M = awning width
- H = projection
- FB = pull-out force per fixing point
- HT | BHT = bracket quantity | width
- BM = no. of fixing points
- 70868. = top fixture bracket assembly 90 mm
- 71818. = top fixture bracket assembly 45 mm

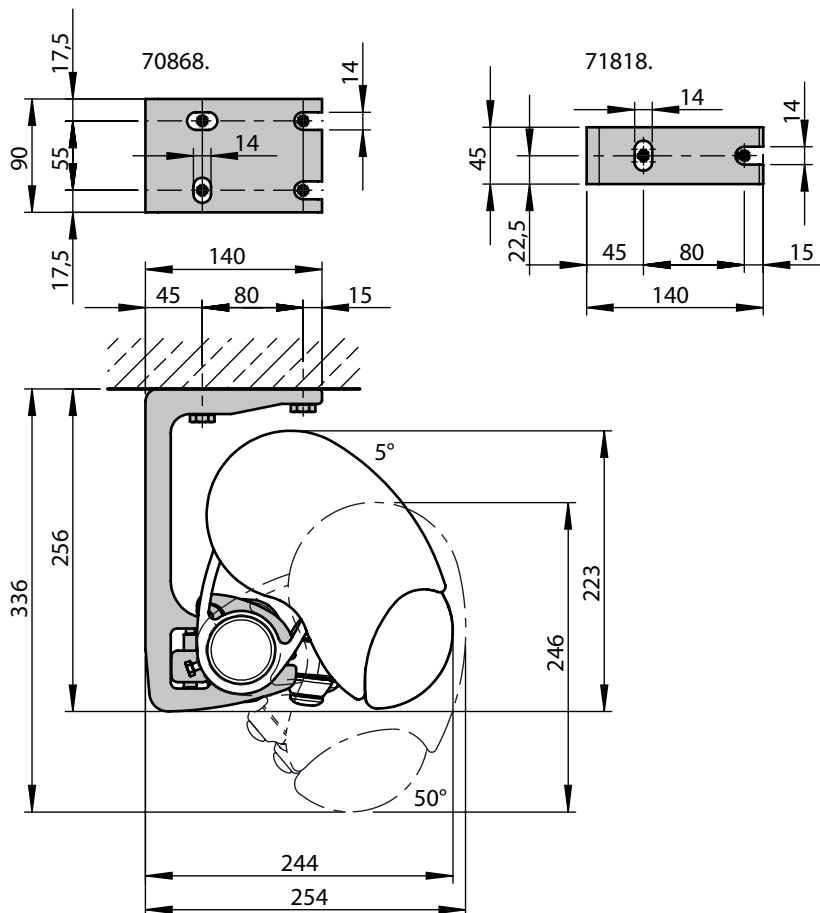

dimensions in mm

Eaves fixture

Torque [Nm = Newton metres] for the fixture bracket in the immediate vicinity of the arm, shear force [N = Newton] per fixing point according to EN 13561, wind resistance class 2

H [cm]	Torque M [cm]										Shear force M [cm]									
	260	310	360	410	460	510	560	610	660		260	310	360	410	460	510	560	610	660	
	Md [Nm]										FS [N]									
150	116	132	147	163	178	194	210	225	241		1418	1617	1815	2014	2212	2411	2610	2808	3007	
200	182	207	232	256	281	306	331	355	380		2154	2454	2753	3053	3353	3653	3952	4252	4552	
250	-	297	333	368	404	440	476	511	616		-	3453	3875	4298	4720	5142	5565	5987	7178	
300	-	-	451	500	548	597	730	786	843		-	-	5190	5756	6323	6889	8388	9042	9696	
350	-	-	-	652	808	883	957	1031	-		-	-	-	7449	9213	10064	10915	11766	-	
HT	2					3					2					3				
BM	8					12					8					12				

The shear force is calculated on the basis of 2 fixing points per bracket, because - depending on the roof pitch - it cannot be guaranteed that 4 fixing points per bracket can be used.

- M = awning width
- H = projection
- Md = torque value for the bracket in the immediate vicinity of the arm
- HT = no. of brackets
- FS = shear force
- BM = no. of fixing points

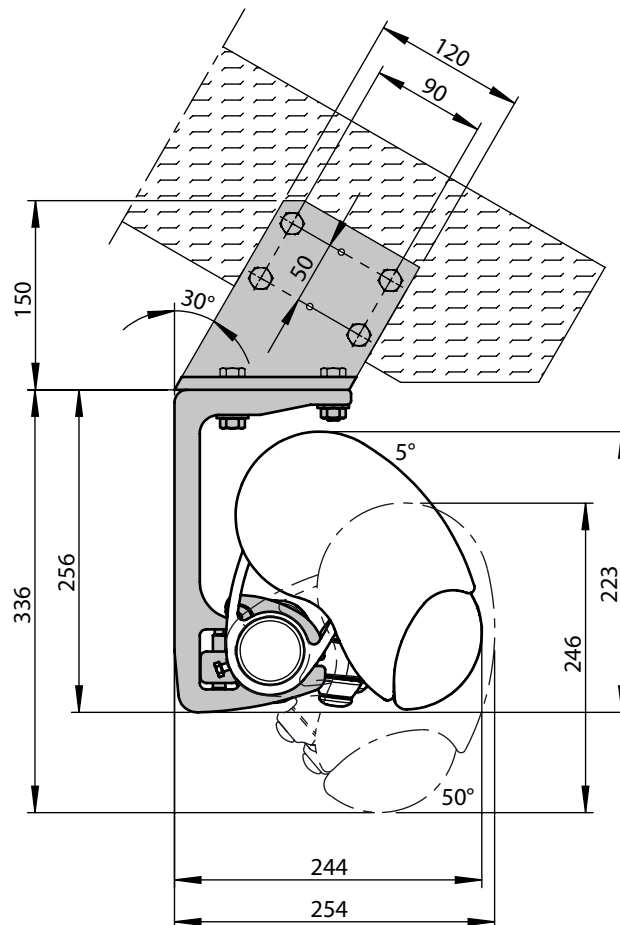

dimensions in mm

Eaves fixture with additional spreader / backing plate

Torque [Nm = Newton metres] for the fixture bracket in the immediate vicinity of the arm, shear force [N = Newton] per fixing point according to EN 13561, wind resistance class 2

H [cm]	Torque M [cm]									Shear force M [cm]								
	260	310	360	410	460	510	560	610	660	260	310	360	410	460	510	560	610	660
	Md [Nm]									FS [N]								
150	116	132	147	163	178	194	210	225	241	710	813	916	1019	1122	1225	1328	1432	1535
200	182	207	232	256	281	306	331	355	380	1041	1189	1338	1487	1635	1784	1933	2081	2230
250	-	297	333	368	404	440	476	511	616	-	1639	1843	2047	2251	2454	2658	2862	3412
300	-	-	451	500	548	597	730	786	843	-	-	2435	2703	2972	3240	3929	4237	4545
350	-	-	-	652	808	883	957	1031	-	-	-	-	3465	4272	4669	5066	5462	-
HT	2				3					2				3				
BM	4				6					4				6				

By using the additional flat fixture plate, the shear force is reduced in comparison with conventional eaves fixture.

- M = awning width
- H = projection
- Md = torque value for the bracket in the immediate vicinity of the arm
- HT = no. of brackets
- FS = shear force
- BM = no. of fixing points

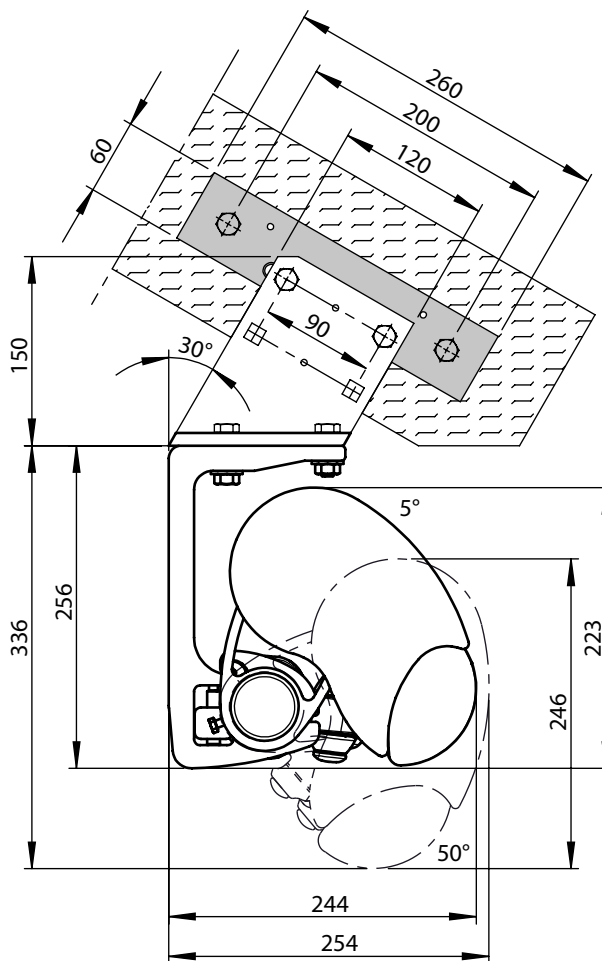

dimensions in mm

Installation using the adjustable eaves fixture bracket

Pull-out force [N=Newton] per upper fixing point according to EN 13561, wind resistance class 2

Compression-proof substrate

M [cm]

260	310	360	410	460	510	560	610	660
-----	-----	-----	-----	-----	-----	-----	-----	-----

Non compression-proof substrate

M [cm]

260	310	360	410	460	510	560	610	660
-----	-----	-----	-----	-----	-----	-----	-----	-----

H [cm]	FB [N]								
150	929	1062	1195	1328	1460	1593	1726	1859	1992
200	1386	1582	1777	1973	2168	2364	2559	2755	2951
250	-	2202	2474	2745	3017	3289	3560	3832	4580
300	-	-	3290	3651	4012	4373	5313	5728	6143
350	-	-	-	4701	5806	6343	6881	7419	-

H [cm]	FB [N]								
150	958	1095	1231	1368	1504	1641	1778	1914	2051
200	1431	1633	1834	2036	2238	2439	2641	2842	3044
250	-	2275	2556	2836	3117	3397	3677	3958	4732
300	-	-	3401	3774	4147	4520	5493	5922	6351
350	-	-	-	4862	6005	6561	7117	7673	-

HT BHT	2 90 mm	2 90 mm 1 45 mm
----------	-----------	------------------------

HT BHT	2 90 mm	2 90 mm 1 45 mm
----------	-----------	------------------------

BM	8	10
----	---	----

BM	8	10
----	---	----

The pull-out force refers to the measurement from the front to the rear fixture points of **140 mm**.

Washers conforming to DIN 9021 must be used.

- M = awning width
- H = projection
- FB = pull-out force per fixing point
- HT | BHT = bracket quantity | width
- BM = no. of fixing points

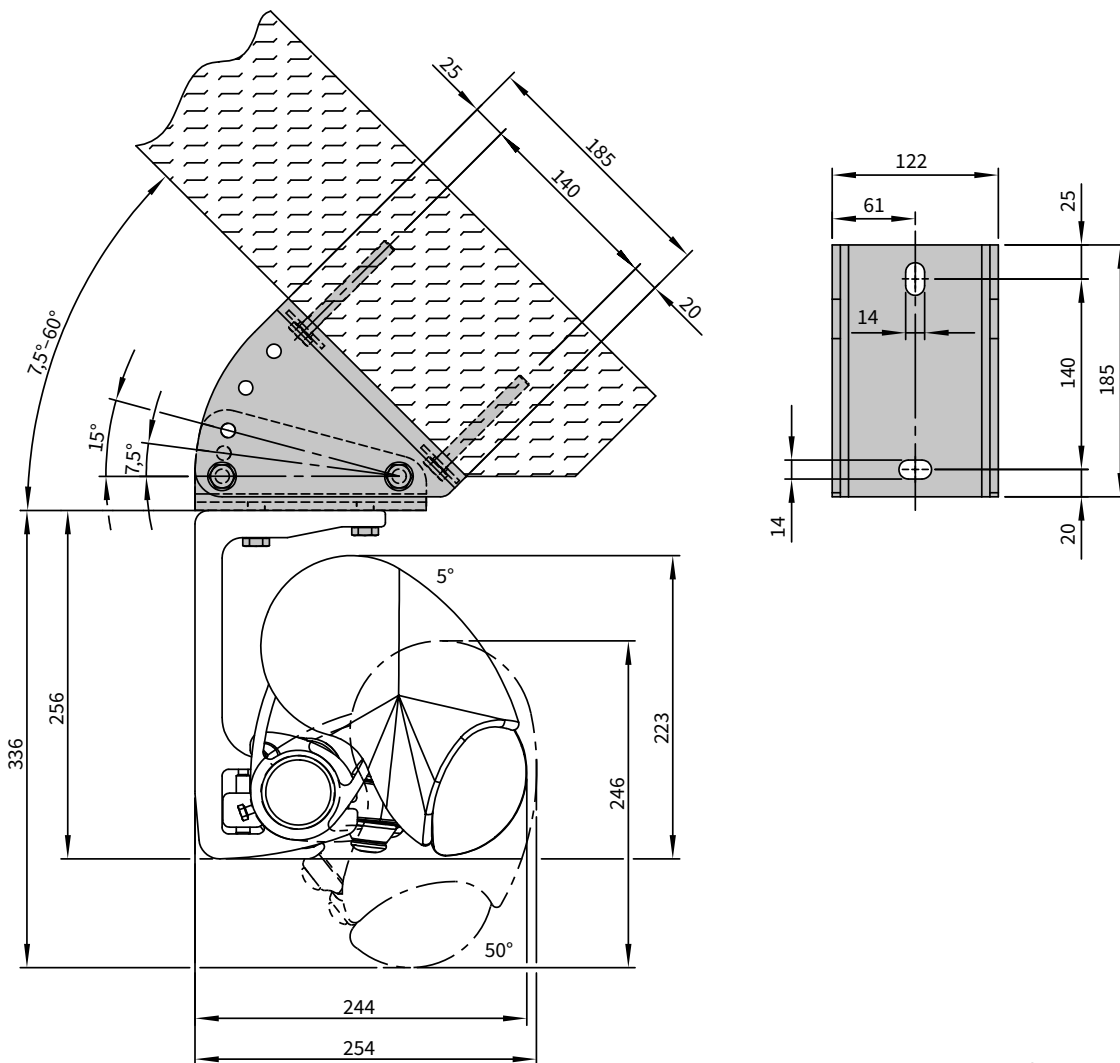

dimensions in mm

Installation with shadeplus / drop valance using the adjustable eaves fixture bracket

Pull-out force [N=Newton] per upper fixing point according to EN 13561, wind resistance class 2

		Compression-proof substrate									Non compression-proof substrate								
		M [cm]									M [cm]								
		260	310	360	410	460	510	560	610	660	260	310	360	410	460	510	560	610	660
H [cm]	FB [N]																		
150	1061	1219	1378	1536	1694	1852	2010	2168	2327	1095	1257	1420	1583	1746	1909	2072	2235	2398	
200	1562	1792	2021	2250	2480	2709	2938	3168	3397	1613	1850	2087	2323	2560	2797	3033	3270	3507	
250	-	2464	2778	3092	3406	3720	4034	4348	5139	-	2547	2871	3195	3519	3844	4168	4492	5310	
300	-	-	3666	4077	4489	4901	5892	6358	6824	-	-	3790	4216	4641	5067	6092	6574	7056	
350	-	-	-	5187	6350	6947	7544	8141	-	-	-	-	5365	6569	7186	7804	8421	-	

HT BHT	2 90 mm	2 90 mm 1 45 mm	2 90 mm	2 90 mm 1 45 mm
BM	8	10	8	10

The pull-out force refers to the measurement from the front to the rear fixture points of **140 mm**.

Washers conforming to DIN 9021 must be used.

- M = awning width
- H = projection
- FB = pull-out force per fixing point
- HT | BHT = bracket quantity | width
- BM = no. of fixing points

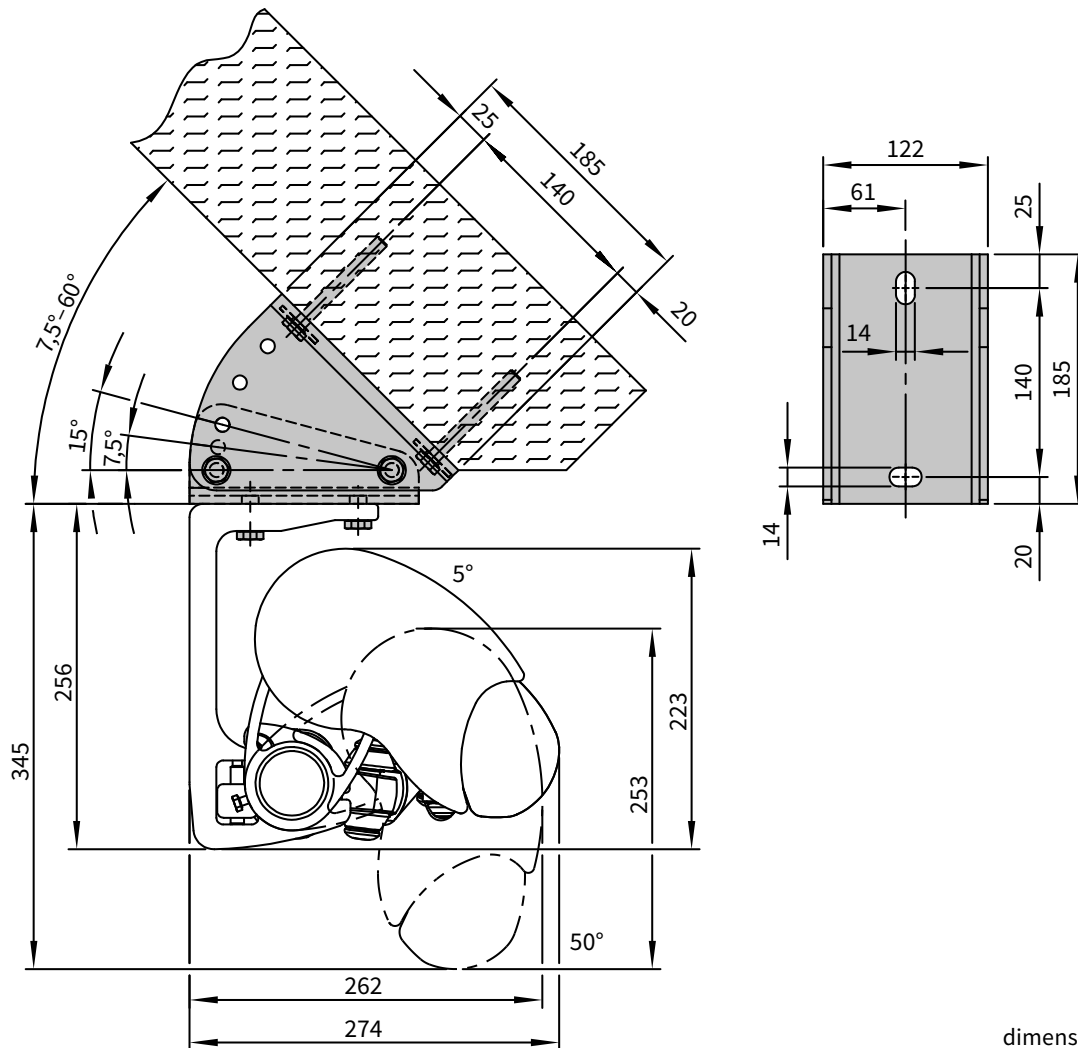

dimensions in mm

Face fixture with manual operation

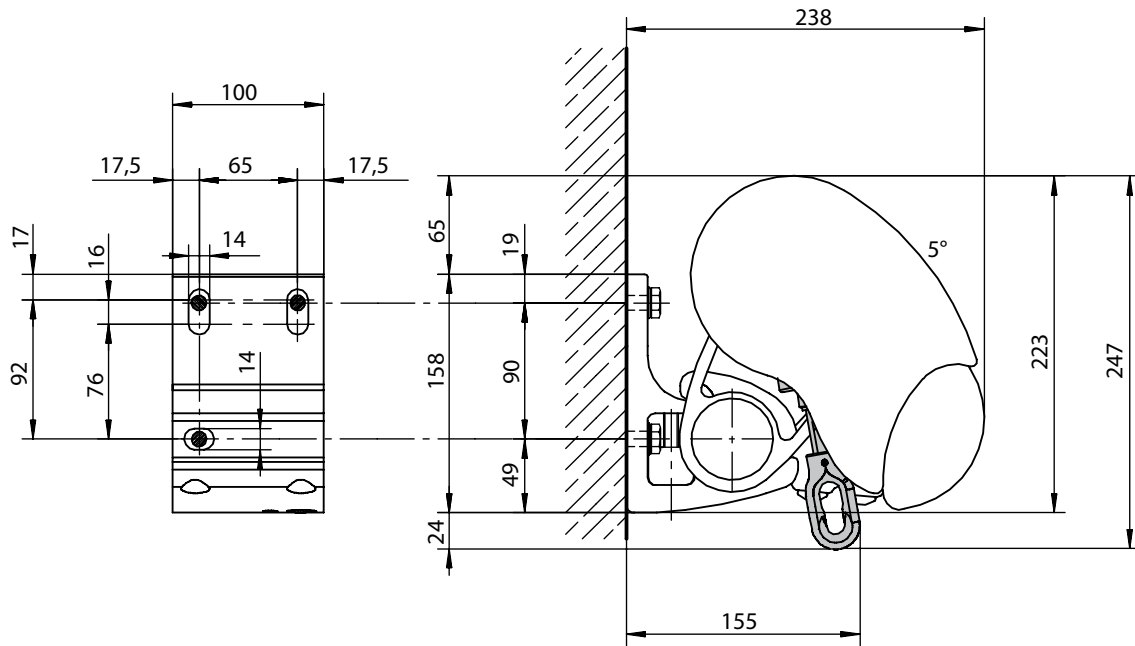

dimensions in mm

Cable exit point in motor-driven units

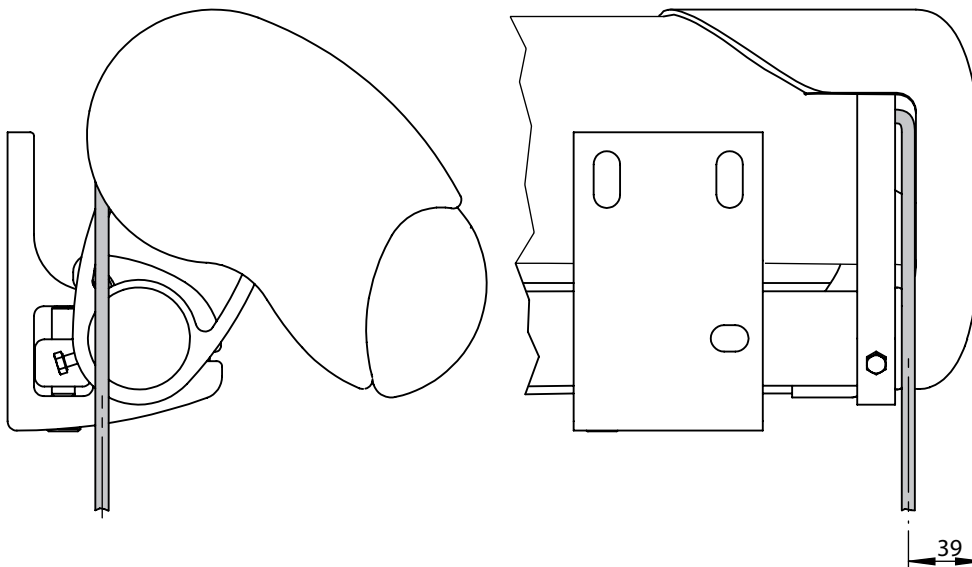

dimensions in mm

Bracket fixture range for awnings with 2 folding arms

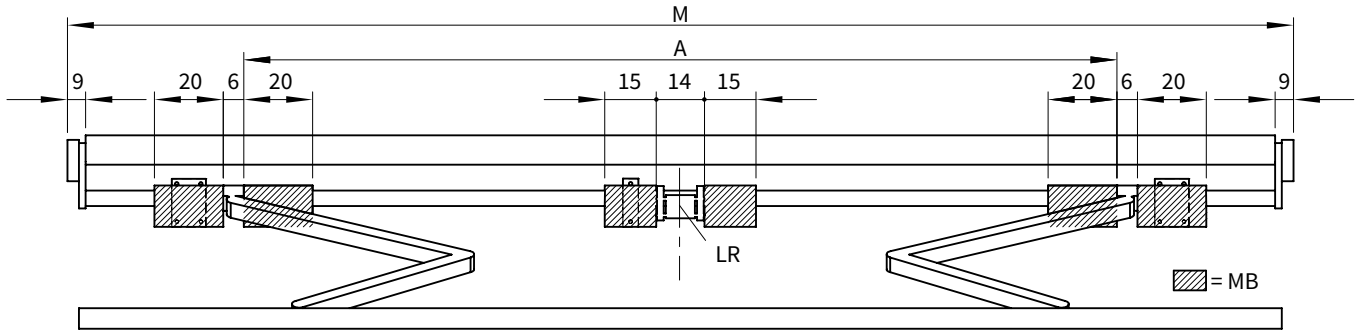

M [cm]	SB →	260	310	360	410	460	510	560	610	660
	ZB →	193–260	261–310	311–360	361–410	411–460	461–510	511–560	561–610	611–660

H [cm] ↓	A [cm]								
150	160*	220	250	280	320	390	425	460	500
200	210**	220*	250	280	320	390	425	460	500
250	-	260**	270*	280	320	390	425	460	500
300	-	-	310**	320*	320	390	425	460	500
350	-	-	-	360**	375*	390	425	460	-

dimensions in cm

W	BHT ↓	HT ↓	
	45 mm	-	1
	100 mm	2	2

DE	45 mm	-	1
	90 mm	2	2

DA	90 mm	2	3
----	-------	---	---

If the brackets cannot be positioned in accordance with this table, make sure the actual measurements are noted on the order form!

* = Coupled units are only available with a junction roller in the standard widths, in the case of other widths please ask us

** = Please note the minimum widths! In the case of small awnings the brackets can only be fitted inside the arms, i.e. the position denoted by measurement A.

A = arm position

BHT = bracket width

DA = eaves fixture

DE = top fixture

GS = cassette support bracket

H = projection

HT = no. of brackets

LR = a rolltex bearing with accompanying bracket is always placed under a central seam (depends on the awning size)

M = awning width

MB = bracket fixture range

SB = standard width

W = face fixture

ZB = intermediate width

dimensions in mm

01
02
03
04
05
06
07
08
09
10
11
12
13
14
15
16
17
18
19
20
21
22
23

Installation dimensions at varying awning pitches

Top fixture

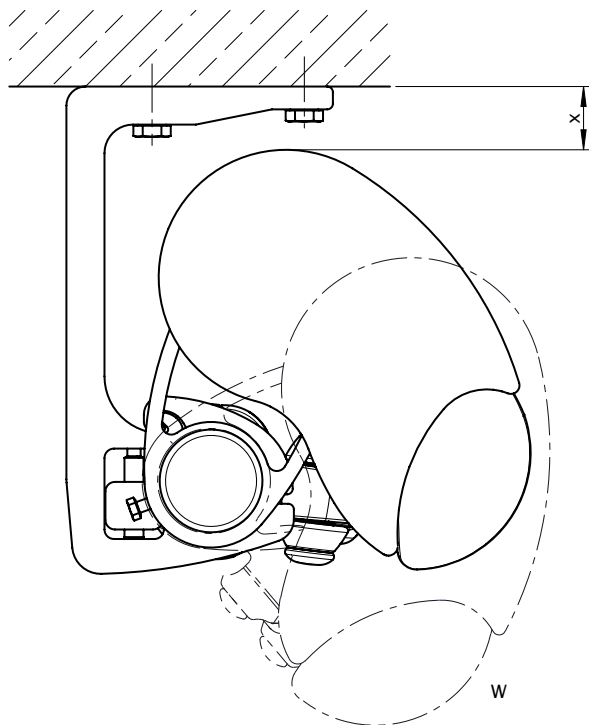

pitch (W)	approx. height in mm (X)
5°	33
10°	38
15°	43
20°	50
25°	57
30°	64
35°	72
40°	81
45°	90
50°	99

Face fixture

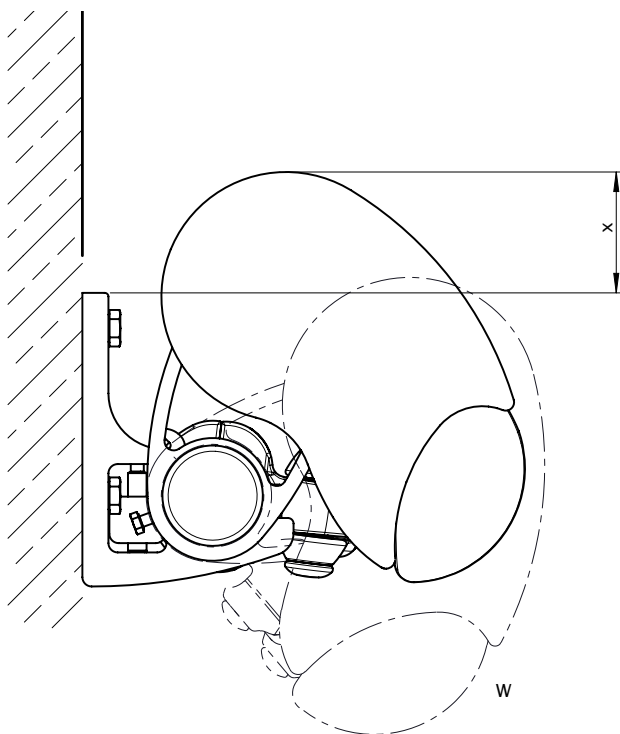

pitch (W)	approx. height in mm (X)
5°	65
10°	65
15°	60
20°	55
25°	49
30°	42
35°	34
40°	26
45°	17
50°	8